

PO1001

1050 Watts Generator

FIRMAN®

Performance series

Running / Starting Watts: 1050/1300



Features & Benefits

- The FIRMAN OHV engine (Max-Pro Series) for longer life/higher performance/lower maintenance.
- Cast iron sleeved engine for long durability with automatic low oil shutdown protection.
- Largest tank in industry with extended run-time (less re-fueling) with built-in tank gauge for convenience.
- Quiet muffler (Whisper Series) with USDA FS certified spark arrester.
- Conveniently located multi-featured control panel with FIRMAN custom designed outlet cover protecting outlets from dirt, dust and debris.
- Bonus accessories including engine oil, oil funnel, tool kit and battery charge cable.
- 3 year warranty.

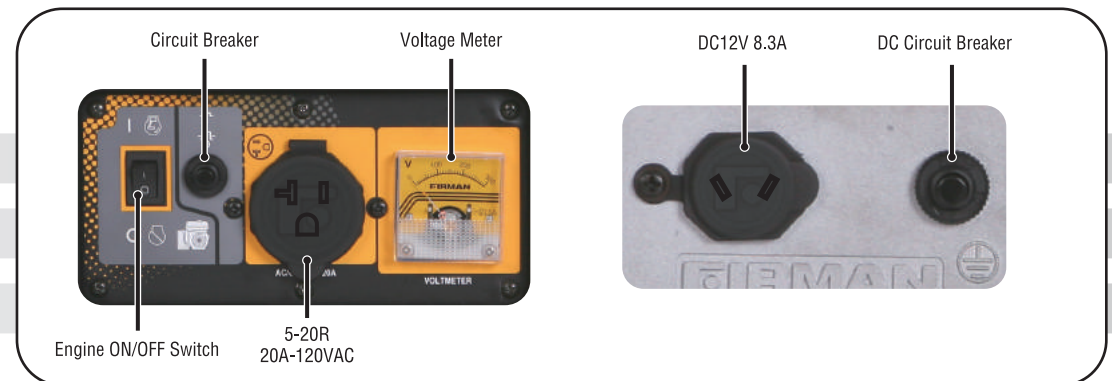

P01001

1050 Watts Generator

FIRMAN®

Performance series

Specification

Model /Rev Level	P01001 / 00
UPC	840876110041
50 States	Yes
California (CARB)	Yes
Canada (CSA)	Yes
Running Watts	1050
Starting Watts	1300
Frequency (Hz)	60
Engine Displacement (cc)	80
Engine Type	OHV
Starting System	Recoil
Cylinder	Single
Fuel Type	Gasoline
Low Oil Shutdown	Yes
Cast Iron Sleeve	Yes
Brushed or Brushless Alternator	Brushless
Automatic Voltage Regulator (AVR)	No
Fuel Tank Volume (Gal)	1.3
Fuel Gauge	Yes
Runtime @50% load (hours)	9.0
USDA FS Certified Spark Arrester	Yes



Handle	No
Wheel	No
Battery	No
Accessories	Oil Bottle-Funnel-Tool Kit -Battery Charger Cable
Warranty Residential / Commercial (years)	3 / 1
Carton LxWxH (inch)	17.9 x 15.4 x 14.2
Unit Weight (lbs)	45.3
Shipping Weight (lbs)	51.7

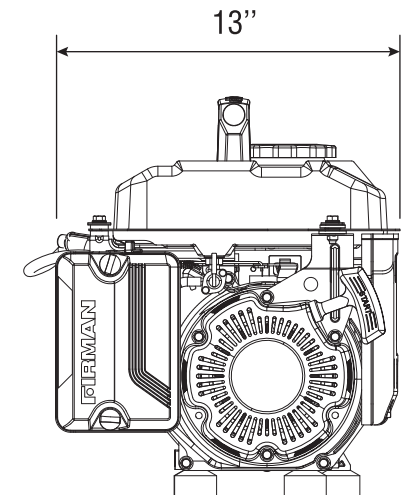
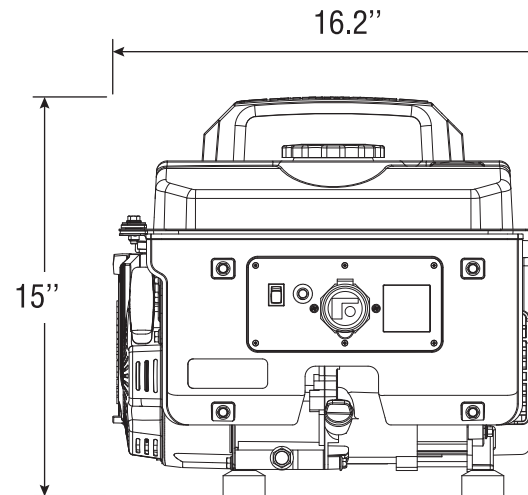

14131 N Rio Vista Blvd Suite 9
Peoria, AZ 85381

1-844-FIRMAN1 (1-844-347-6261)

www.firmangenerators.com

PO1201

1200 Watts Generator

FIRMAN®

Performance series

Running / Starting Watts: 1200/1500



Features & Benefits

- The FIRMAN OHV engine (Max-Pro Series) for longer life/higher performance/lower maintenance.
- Cast iron sleeved (CIS) engine for long durability with automatic low oil shutdown (LOS) protection.
- Largest tank in industry with extended run-time (less re-fueling) with built-in tank gauge for convenience.
- Quiet muffler (Whisper Series) with USDA FS certified spark arrester.
- Conveniently located multi-featured control panel with FIRMAN custom designed outlet cover protecting outlets from dirt, dust and debris.
- Durable compact roll-cage frame design with 0.75" steel tubing.
- Bonus accessories including engine oil, oil funnel and tool kit.
- 3 years warranty: best in industry.

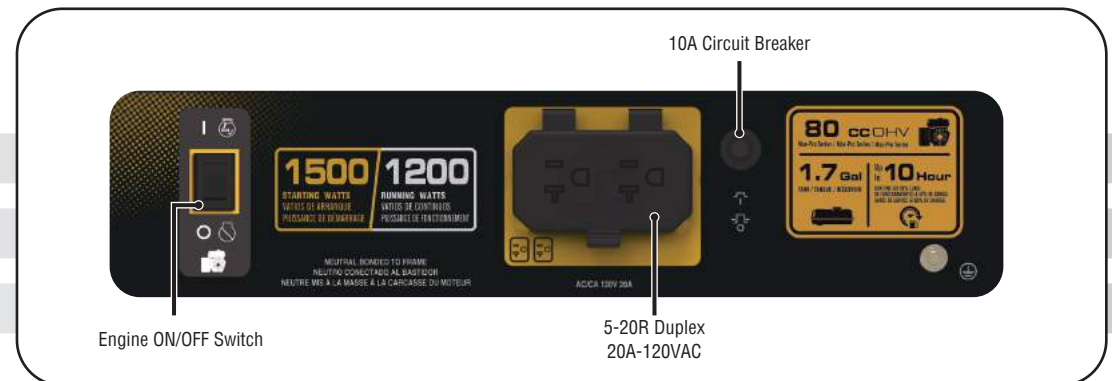

P01201

1200 Watts Generator

FIRMAN®

Performance series

Specification

Model /Rev Level	P01201 / 00
UPC	840876112014
49 States	Yes
California (CARB)	No
Canada (CSA)	No
Running Watts	1200
Starting Watts	1500
Frequency (Hz)	60
Engine Displacement (cc)	80
Engine Type	OHV
Starting System	Recoil
Cylinder	Single
Fuel Type	Gasoline
Low Oil Shutdown	Yes
Cast Iron Sleeve	Yes
Brushed or Brushless Alternator	Brushless
Automatic Voltage Regulator (AVR)	No
Fuel Tank Volume (Gal)	1.7
Fuel Gauge	Yes
Runtime @50% load (hours)	10.0
USDA FS Certified Spark Arrester	Yes



Handle	No
Wheel	No
Battery	No
Accessories	Oil Bottle-Funnel-Tool Kit
Warranty Residential / Commercial (years)	3 / 1
Carton LxWxH (inch)	20.3 x 15.8 x 17.6
Unit Weight (lbs)	54
Shipping Weight (lbs)	61

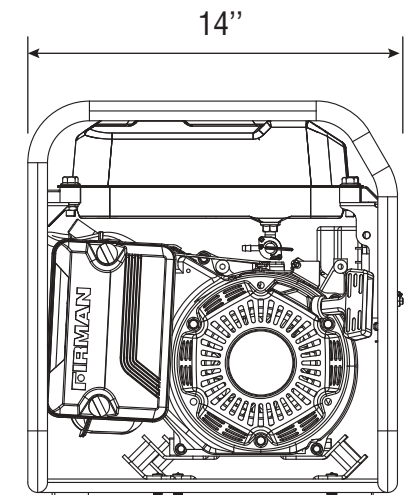
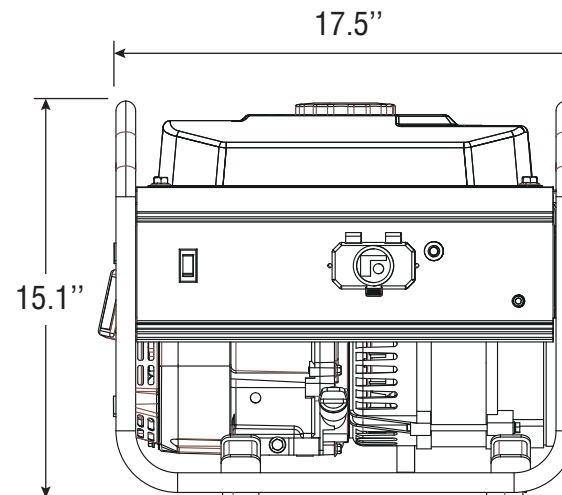

P03601

3650 Watts Generator

FIRMAN®

Performance series

Running / Starting Watts: 3650/4550

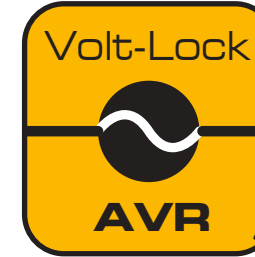
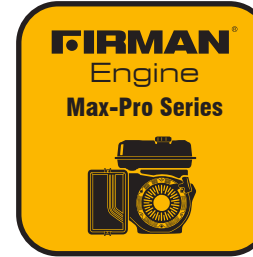

Features & Benefits

- The FIRMAN OHV engine (Max-Pro Series) for longer life/higher performance/lower maintenance.
- Cast iron sleeved (CIS) engine for long durability with automatic low oil shutdown (LOS) protection.
- Largest tank in industry with extended run-time (less re-fueling) with built-in tank gauge for convenience.
- Quiet muffler (Whisper Series) with USDA FS certified spark arrester.
- Conveniently located multi-featured control panel with FIRMAN custom designed outlet cover protecting outlets from dirt, dust and debris.
- 4 in 1 Data-Minder monitors running hours, voltage and frequency in conjunction with our low oil indicator light.
- Durable compact roll-cage frame design with 1.0" steel tubing.
- FIRMAN new designed AVR (Automatic Voltage Regulator) VC (Volt-Lock) Series.
- Bonus accessories including engine oil, oil funnel and tool kit.
- 3 years warranty: best in industry.

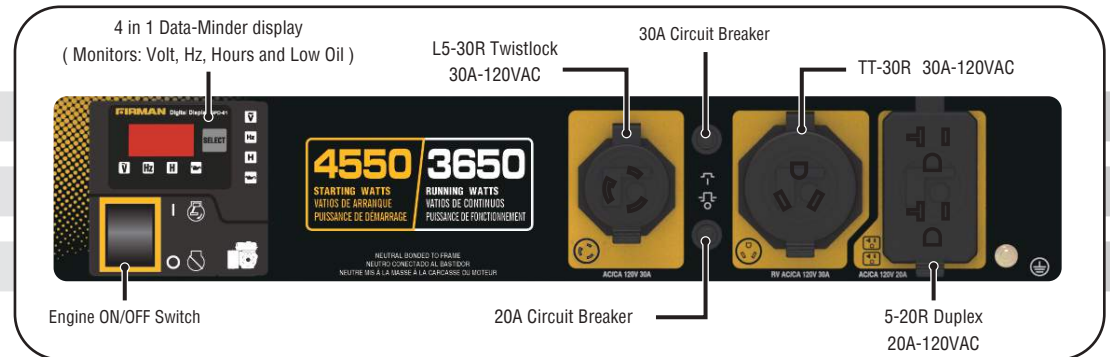

P03601

3650 Watts Generator

FIRMAN®

Performance series

Specification

Model /Rev Level	P03601 / 00
UPC	840876136010
49 States	Yes
California (CARB)	No
Canada (CSA)	No
Running Watts	3650
Starting Watts	4550
Frequency (Hz)	60
Engine Displacement (cc)	208
Engine Type	OHV
Starting System	Recoil
Cylinder	Single
Fuel Type	Gasoline
Low Oil Shutdown	Yes
Cast Iron Sleeve	Yes
Brushed or Brushless Alternator	Brushed
Automatic Voltage Regulator (AVR)	Yes
Fuel Tank Volume (Gal)	5.0
Fuel Gauge	Yes
Runtime @50% load (hours)	14.0
USDA FS Certified Spark Arrester	Yes



Handle	No
Wheel	No
Battery	No
Accessories	Oil Bottle-Funnel-Tool Kit
Warranty Residential / Commercial (years)	3 / 1
Carton LxWxH (inch)	24 x 18.1 x 19.9
Unit Weight (lbs)	101.5
Shipping Weight (lbs)	110

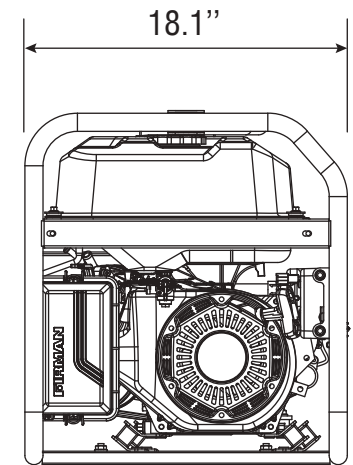
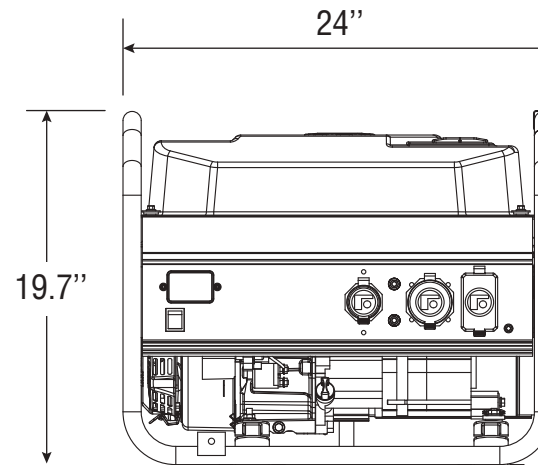

FIRMAN

www.firmangenerators.com

P03602

3650 Watts Generator

FIRMAN®

Performance series

Running / Starting Watts: 3650/4550

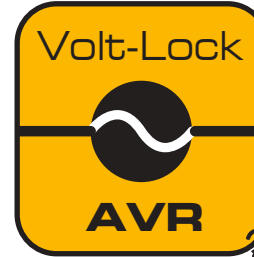

Features & Benefits

- The FIRMAN OHV engine (Max-Pro Series) for longer life/higher performance/lower maintenance.
- Cast iron sleeved (CIS) engine for long durability with automatic low oil shutdown (LOS) protection.
- Largest tank in industry with extended run-time (less re-fueling) with built-in tank gauge for convenience.
- Quiet muffler (Whisper Series) with USDA FS certified spark arrester.
- Conveniently located multi-featured control panel with FIRMAN custom designed outlet cover protecting outlets from dirt, dust and debris.
- 4 in 1 Data-Minder monitors running hours, voltage and frequency in conjunction with our low oil indicator light.
- Wheel Kit with heavy duty and over size flat free wheels with high leverage single folding handle with grip for easy maneuver.
- Durable compact roll-cage frame design with 1.0" steel tubing.
- FIRMAN new designed AVR (Automatic Voltage Regulator) VC (Volt-Lock) Series.
- Bonus accessories including engine oil, oil funnel and tool kit.
- 3 years warranty: best in industry.

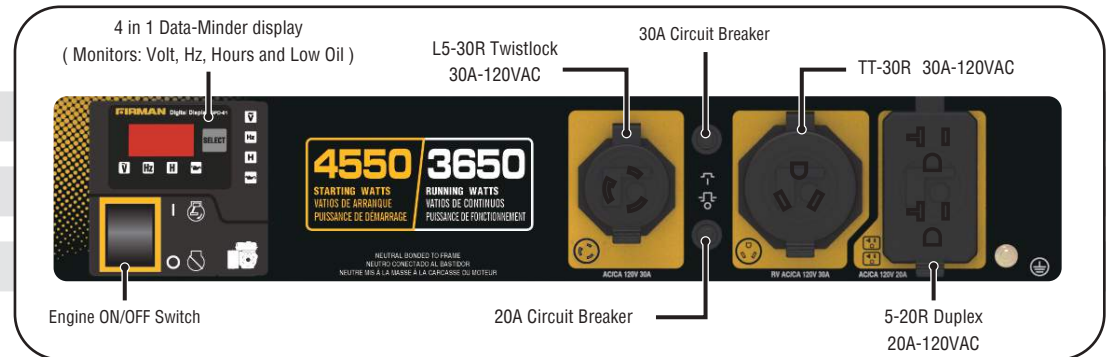

P03602

3650 Watts Generator

FIRMAN®

Performance series

Specification

Model /Rev Level	P03602 / 00
UPC	840876136027
49 States	Yes
California (CARB)	No
Canada (CSA)	No
Running Watts	3650
Starting Watts	4550
Frequency (Hz)	60
Engine Displacement (cc)	208
Engine Type	OHV
Starting System	Recoil
Cylinder	Single
Fuel Type	Gasoline
Low Oil Shutdown	Yes
Cast Iron Sleeve	Yes
Brushed or Brushless Alternator	Brushed
Automatic Voltage Regulator (AVR)	Yes
Fuel Tank Volume (Gal)	5.0
Fuel Gauge	Yes
Runtime @50% load (hours)	14.0
USDA FS Certified Spark Arrester	Yes



Handle	Single Folding
Wheel	8.0" Flat Free
Battery	No
Accessories	Oil Bottle-Funnel-Tool Kit
Warranty Residential / Commercial (years)	3 / 1
Carton LxWxH (inch)	27.2 x 18.1 x 19.9
Unit Weight (lbs)	108.5
Shipping Weight (lbs)	117

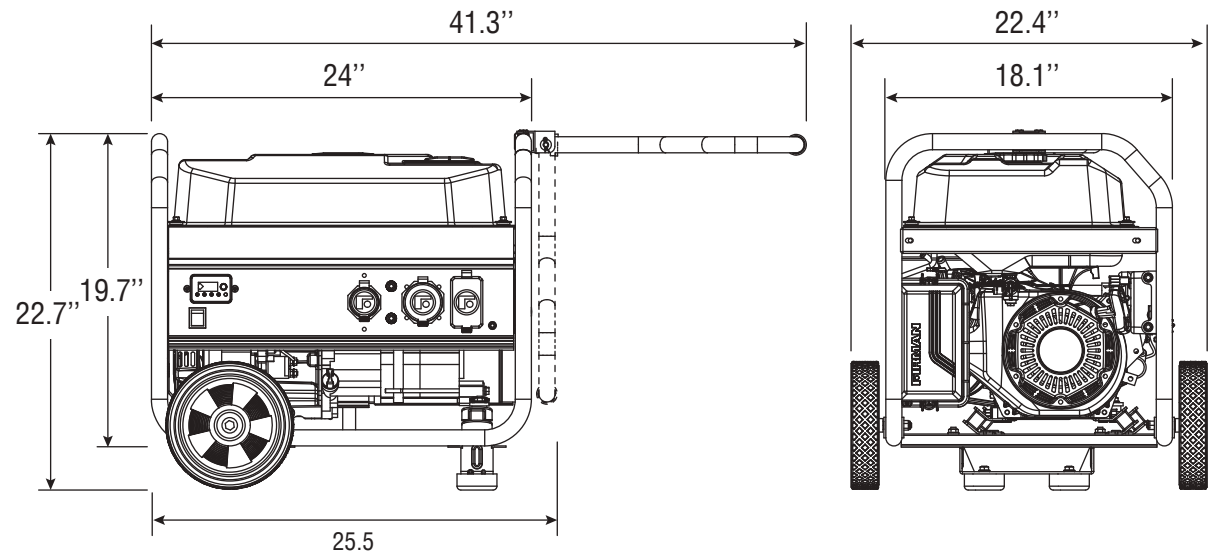

FIRMAN

www.firmangenerators.com

P03603

3650 Watts Generator

FIRMAN®

Performance series

Running / Starting Watts: 3650/4550



Features & Benefits

- The FIRMAN OHV remote start engine (Max-Pro Series) for longer life/higher performance/lower maintenance.
- Remote up to 55 yards away for ease of starting and shut down.
- Cast iron sleeved (CIS) engine for long durability with automatic low oil shutdown (LOS) protection.
- Largest tank in industry with extended run-time (less re-fueling) with built-in tank gauge for convenience.
- Quiet muffler (Whisper Series) with USDA FS certified spark arrester.
- Conveniently located multi-featured control panel with FIRMAN custom designed outlet cover protecting outlets from dirt, dust and debris.
- 4 in 1 Data-Minder monitors running hours, voltage and frequency in conjunction with our low oil indicator light.
- Wheel Kit with heavy duty and over size flat free wheels with high leverage single folding handle with grip for easy maneuver.
- Durable compact roll-cage frame design with 1.0" steel tubing.
- FIRMAN new designed AVR (Automatic Voltage Regulator) VC (Volt-Lock) Series.
- Bonus accessories including engine oil, oil funnel and tool kit.
- 3 years warranty: best in industry.

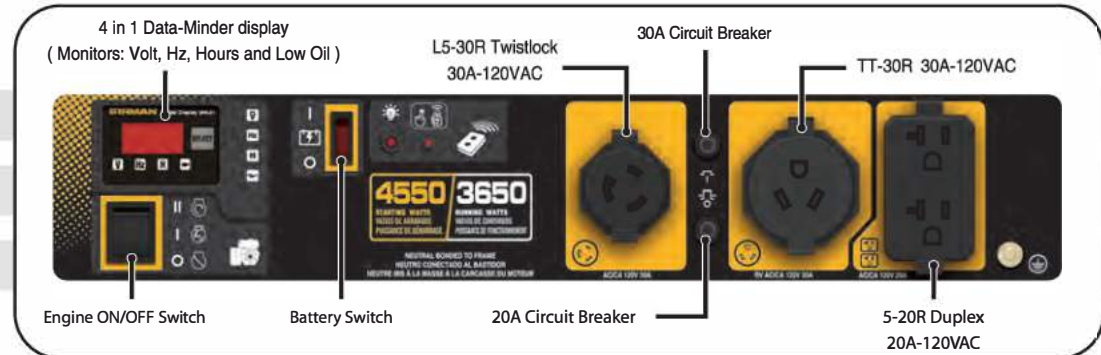

P03603

3650 Watts Generator



Performance series

Specification

Model /Rev Level	P03603 / 01
UPC	840876136034
49 States	Yes
California (CARB)	No
Canada (CSA)	Yes
Running Watts	3650
Starting Watts	4550
Frequency (Hz)	60
Engine Displacement (cc)	208
Engine Type	OHV
Starting System	Recoil/Electric/Remote
Cylinder	Single
Fuel Type	Gasoline
Low Oil Shutdown	Yes
Cast Iron Sleeve	Yes
Brushed or Brushless Alternator	Brushed
Automatic Voltage Regulator (AVR)	Yes
Fuel Tank Volume (Gal)	5.0
Fuel Gauge	Yes
Runtime @50% load (hours)	14.0
USDA FS Certified Spark Arrester	Yes



Handle	Single Folding
Wheel	8.0" Flat Free
Battery	Yes
Accessories	Oil Bottle-Funnel-Tool Kit
Warranty Residential / Commercial (years)	3 / 1
Carton LxWxH (inch)	27.2 x 18.1 x 19.9
Unit Weight (lbs)	119.5
Shipping Weight (lbs)	128

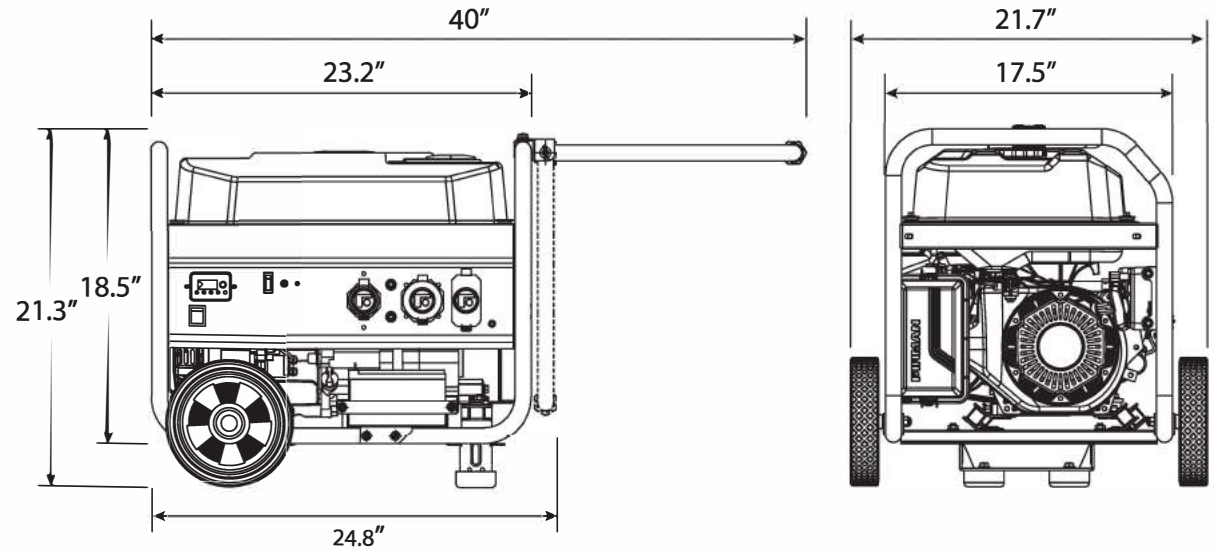

P03612

3650 Watts Generator

FIRMAN®

Performance series

Running / Starting Watts: 3650/4550



Features & Benefits

- The FIRMAN OHV engine (Max-Pro Series) for longer life/higher performance/lower maintenance.
- Remote up to 55 yards away for ease of starting and shut down.
- Cast iron sleeved engine for long durability with automatic low oil shutdown protection.
- Largest tank in the industry with extended run-time (less re-fueling) with integrated fuel gauge for convenience.
- Quiet muffler (Whisper Series) with USDA FS certified spark arrester.
- Conveniently located multi-featured control panel with FIRMAN custom designed outlet cover protecting outlets from dirt, dust and debris.
- 4 in 1 Data-Minder monitors running hours, voltage and frequency in conjunction with our low oil indicator light.
- Wheel Kit with heavy duty and over size flat free wheels with high leverage single folding handle with grip for easy maneuver.
- Durable compact roll-cage frame design with 1.0" steel tubing.
- FIRMAN newly designed AVR (Automatic Voltage Regulator) VL (Volt-Lock) Series.
- Bonus accessories including engine oil, oil funnel and tool kit.
- Included battery for your convenience.
- 3 year warranty: best in industry.

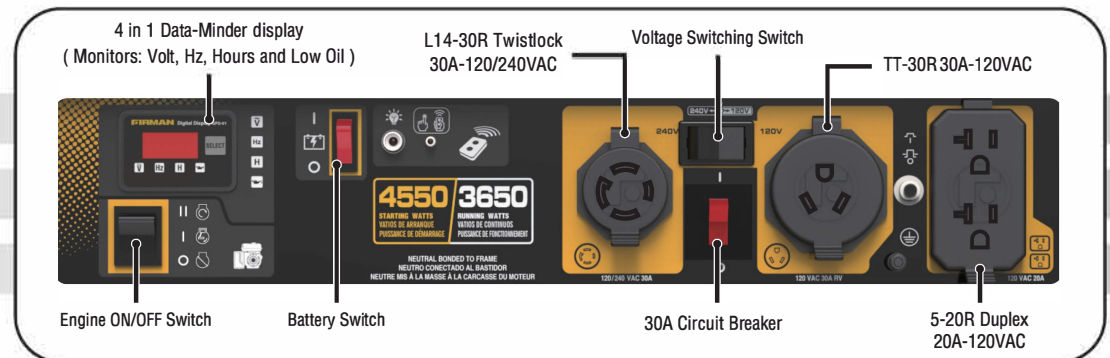

P03612

3650 Watts Generator



Performance series

Specification

Model /Rev Level	P03612 / 01
UPC	840876136126
49 States	Yes
California (CARB)	No
Canada (CETL)	Yes
Running Watts	3650
Starting Watts	4550
Frequency (Hz)	60
Engine Displacement (cc)	208
Engine Type	OHV
Starting System	Recoil/Electric/Remote
Cylinder	Single
Fuel Type	Gasoline
Low Oil Shutdown	Yes
Cast Iron Sleeve	Yes
Brushed or Brushless Alternator	Brushed
Automatic Voltage Regulator (AVR)	Yes
Fuel Tank Volume (Gal)	5.0
Fuel Gauge	Yes
Runtime @50% load (hours)	14.0
USDA FS Certified Spark Arrester	Yes



Handle	Single Folding
Wheel	8.0" Flat Free
Battery	Yes
Accessories	Oil Bottle-Funnel-Tool Kit
Warranty Residential / Commercial	3 Yrs Ltd / 90 Days
Carton LxWxH (inch)	27.2 x 18.1 x 19.9
Unit Weight (lbs)	119.5
Shipping Weight (lbs)	128

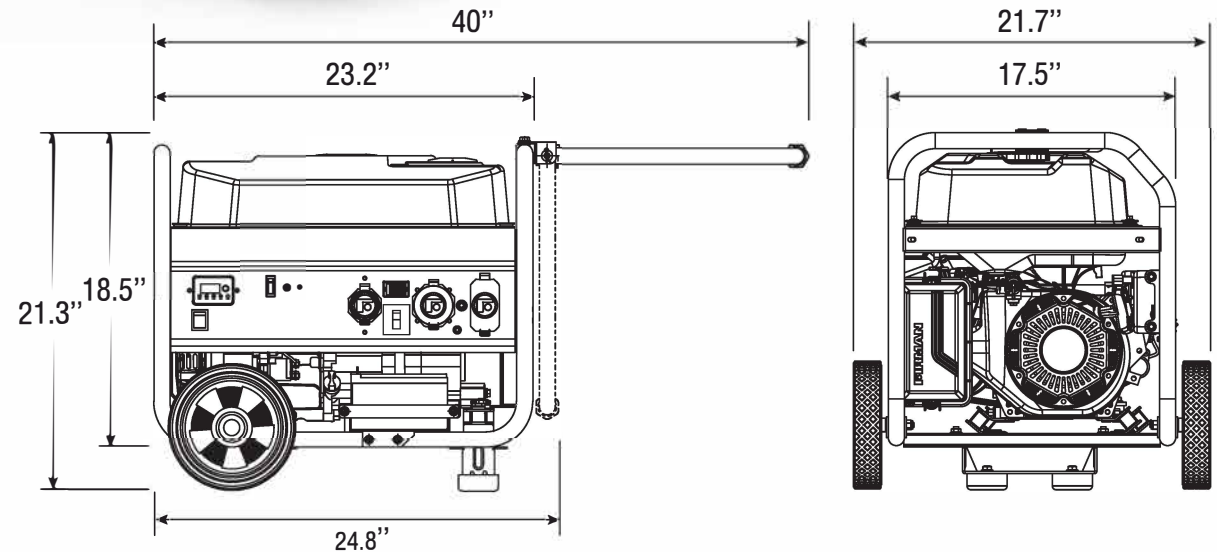

14131 N Rio Vista Blvd Suite 9
Peoria, AZ 85381

1-844-FIRMAN1

(1-844-347-6261)

www.firmangenerators.com

P03607

3650 Watts Generator

FIRMAN®

Performance series

Running / Starting Watts: 3650/4550



Features & Benefits

- The FIRMAN OHV engine (Max-Pro Series) for longer life/higher performance/lower maintenance.
- Cast iron sleeved engine for long durability with automatic low oil shutdown protection.
- Largest tank in the industry with extended run-time (less re-fueling) with integrated fuel gauge for convenience.
- Quiet muffler (Whisper Series) with USDA FS certified spark arrester.
- Conveniently located multi-featured control panel with FIRMAN custom designed outlet cover protecting outlets from dirt, dust and debris.
- 4 in 1 Data-Minder monitors running hours, voltage and frequency in conjunction with our low oil indicator light.
- Durable compact roll-cage frame design with 1.0" steel tubing.
- FIRMAN new designed AVR (Automatic Voltage Regulator) VC (Volt-Lock) Series.
- Bonus accessories including engine oil, oil funnel and tool kit.
- 3 year warranty: best in industry.

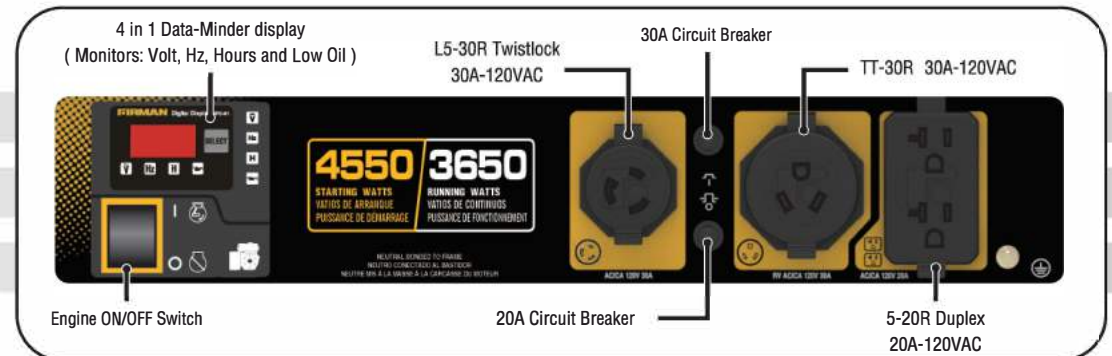

P03607

3650 Watts Generator

FIRMAN®

Performance series

Specification

Model /Rev Level	P03607 / 00
UPC	840876136072
49 States	Yes
California (CARB)	Yes
Canada (CETL)	No
Running Watts	3650
Starting Watts	4550
Frequency (Hz)	60
Engine Displacement (cc)	208
Engine Type	OHV
Starting System	Recoil
Cylinder	Single
Fuel Type	Gasoline
Low Oil Shutdown	Yes
Cast Iron Sleeve	Yes
Brushed or Brushless Alternator	Brushed
Automatic Voltage Regulator (AVR)	Yes
Fuel Tank Volume (Gal)	5.0
Fuel Gauge	Yes
Runtime @50% load (hours)	14.0
USDA FS Certified Spark Arrester	Yes



Handle	No
Wheel	No
Battery	No
Accessories	Oil Bottle-Funnel-Tool Kit
Warranty Residential / Commercial	3 Yrs Ltd / 90 Days
Carton LxWxH (inch)	24 x 18.1 x 19.9
Unit Weight (lbs)	101.5
Shipping Weight (lbs)	110

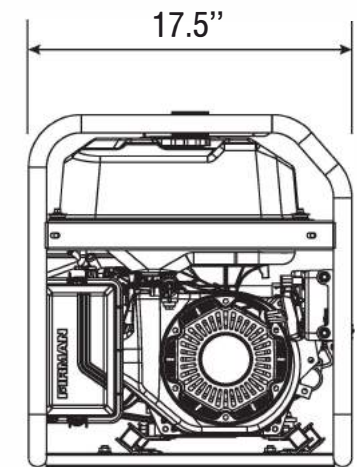
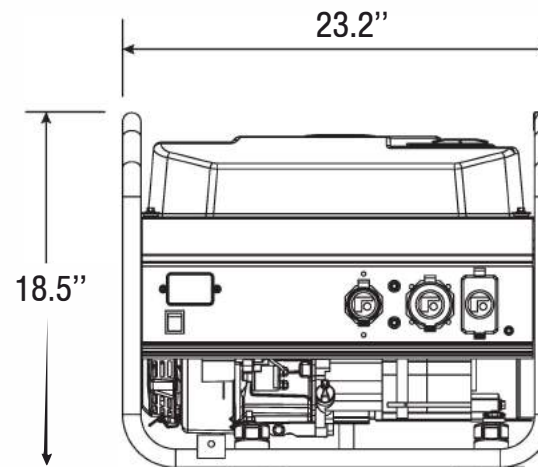

P03608

3650 Watts Generator

FIRMAN®

Performance series

Running / Starting Watts: 3650/4550



Features & Benefits

- The FIRMAN OHV engine (Max-Pro Series) for longer life/higher performance/lower maintenance.
- Remote up to 55 yards away for ease of starting and shut down.
- Cast iron sleeved engine for long durability with automatic low oil shutdown protection.
- Largest tank in the industry with extended run-time (less re-fueling) with integrated fuel gauge for convenience.
- Quiet muffler (Whisper Series) with USDA FS certified spark arrester.
- Conveniently located multi-featured control panel with FIRMAN custom designed outlet cover protecting outlets from dirt, dust and debris.
- 4 in 1 Data-Minder monitors running hours, voltage and frequency in conjunction with our low oil indicator light.
- Wheel Kit with heavy duty and over size flat free wheels with high leverage single folding handle with grip for easy maneuver.
- Durable compact roll-cage frame design with 1.0" steel tubing.
- FIRMAN newly designed AVR (Automatic Voltage Regulator) VL (Volt-Lock) Series.
- Bonus accessories including engine oil, oil funnel and tool kit.
- Included battery for your convenience.
- 3 year warranty: best in industry.

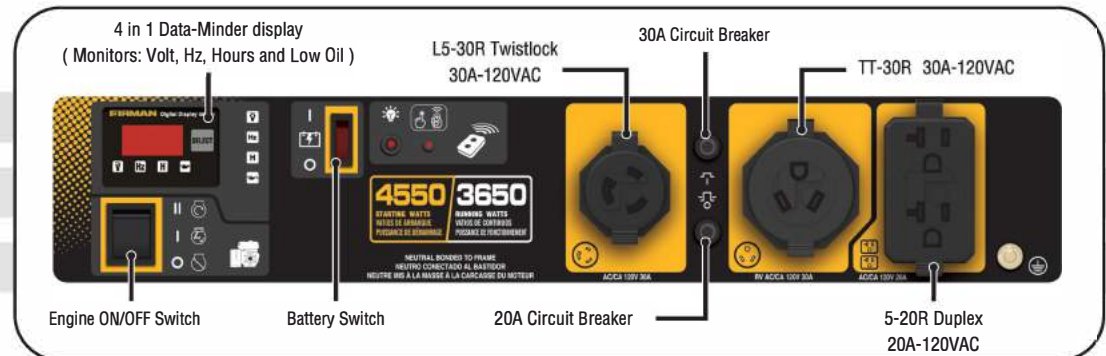

P03608

3650 Watts Generator

FIRMAN®

Performance series

Specification

Model /Rev Level	P03608 / 00
UPC	840876136089
49 States	Yes
California (CARB)	Yes
Canada (CSA)	No
Running Watts	3650
Starting Watts	4550
Frequency (Hz)	60
Engine Displacement (cc)	208
Engine Type	OHV
Starting System	Recoil / Electric
Cylinder	Single
Fuel Type	Gasoline
Low Oil Shutdown	Yes
Cast Iron Sleeve	Yes
Brushed or Brushless Alternator	Brushed
Automatic Voltage Regulator (AVR)	Yes
Fuel Tank Volume (Gal)	5.0
Fuel Gauge	Yes
Runtime @50% load (hours)	14.0
USDA FS Certified Spark Arrester	Yes



Handle	Single Folding
Wheel	8.0" Flat Free
Battery	Yes
Accessories	Oil Bottle-Funnel-Tool Kit
Warranty Residential / Commercial	3 Yrs Ltd / 90 Days
Carton LxWxH (inch)	27.2 x 18.1 x 19.9
Unit Weight (lbs)	119.5
Shipping Weight (lbs)	128

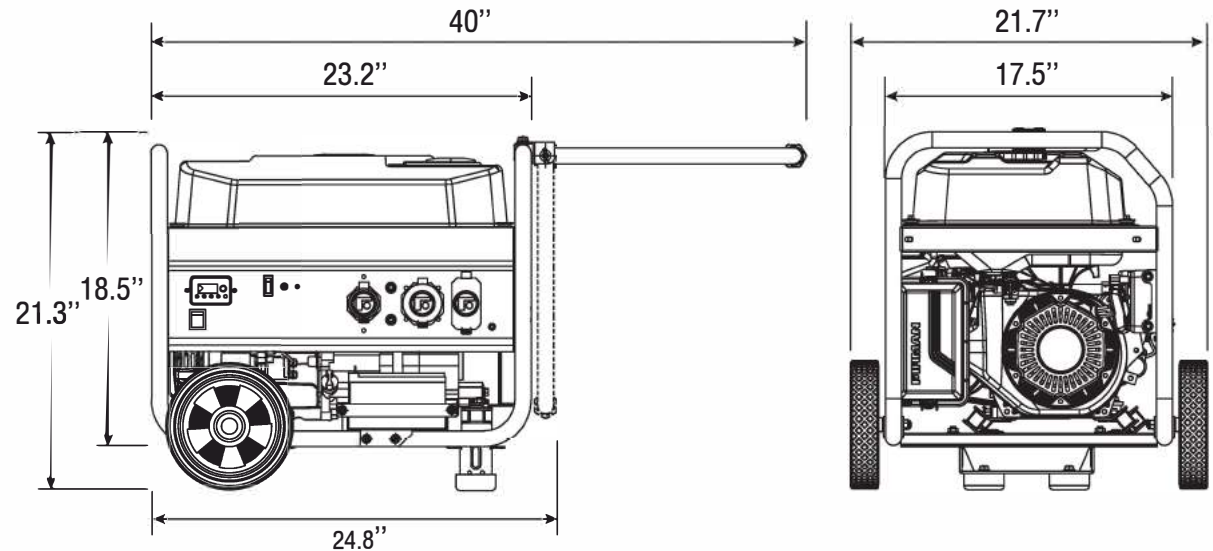

P03609

3650 Watts Generator



Performance series

Running / Starting Watts: 3650/4550

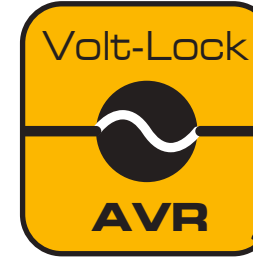

Features & Benefits

- The FIRMAN OHV engine (Max-Pro Series) for longer life/higher performance/lower maintenance.
- Cast iron sleeved (CIS) engine for long durability with automatic low oil shutdown (LOS) protection.
- Largest tank in industry with extended run-time (less re-fueling) with built-in tank gauge for convenience.
- Quiet muffler (Whisper Series) with USDA FS certified spark arrester.
- Conveniently located multi-featured control panel with FIRMAN custom designed outlet cover protecting outlets from dirt, dust and debris.
- 4 in 1 Data-Minder monitors running hours, voltage and frequency in conjunction with our low oil indicator light.
- Durable compact roll-cage frame design with 1.0" steel tubing.
- FIRMAN new designed AVR (Automatic Voltage Regulator) VC (Volt-Lock) Series.
- Bonus accessories including engine oil, oil funnel and tool kit.
- 3 years warranty: best in industry.

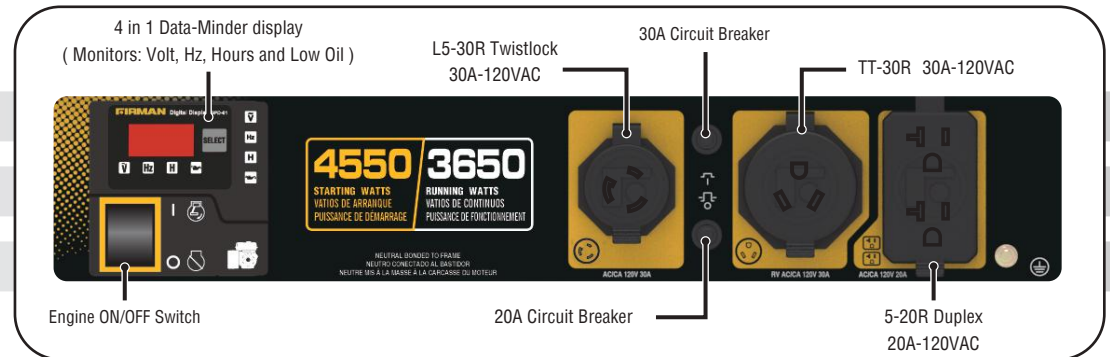

P03609

3650 Watts Generator

FIRMAN®

Performance series

Specification

Model /Rev Level	P03609 / 00
UPC	
49 States	Yes
California (CARB)	No
Canada (CSA)	No
Running Watts	3650
Starting Watts	4550
Frequency (Hz)	60
Engine Displacement (cc)	208
Engine Type	OHV
Starting System	Recoil
Cylinder	Single
Fuel Type	Gasoline
Low Oil Shutdown	Yes
Cast Iron Sleeve	Yes
Brushed or Brushless Alternator	Brushed
Automatic Voltage Regulator (AVR)	Yes
Fuel Tank Volume (Gal)	5.0
Fuel Gauge	Yes
Runtime @50% load (hours)	14.0
USDA FS Certified Spark Arrester	Yes



Handle	No
Wheel	No
Battery	No
Accessories	Oil Bottle-Funnel-Tool Kit
Warranty Residential / Commercial (years)	3 / 1
Carton LxWxH (inch)	24 x 18.1 x 19.9
Unit Weight (lbs)	101.5
Shipping Weight (lbs)	110

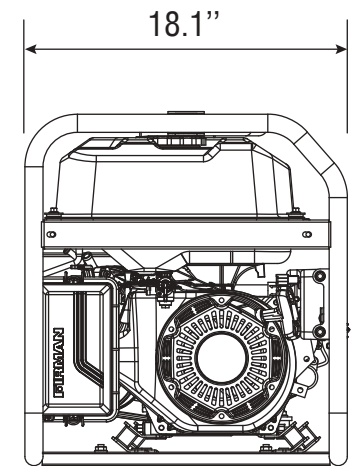
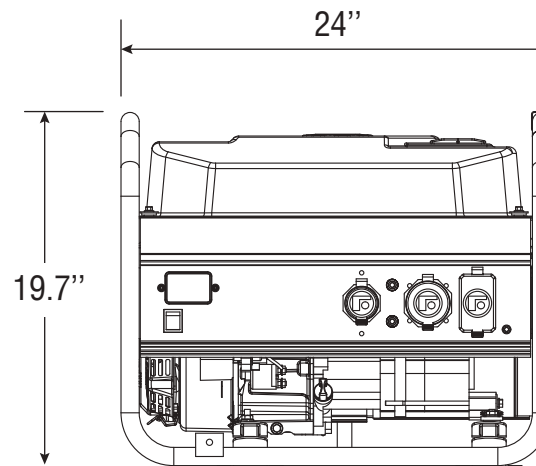

FIRMAN

www.firmangenerators.com

P03611

3650 Watts Generator



Performance series

Running / Starting Watts: 3650/4550

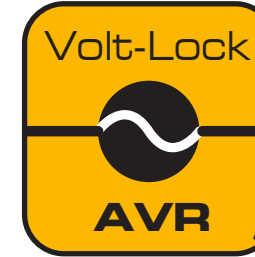
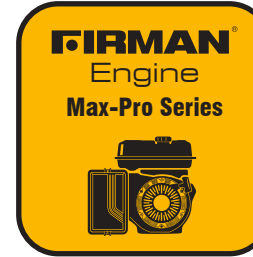

Features & Benefits

- The FIRMAN OHV engine (Max-Pro Series) for longer life/higher performance/lower maintenance.
- Cast iron sleeved (CIS) engine for long durability with automatic low oil shutdown (LOS) protection.
- Largest tank in industry with extended run-time (less re-fueling) with built-in tank gauge for convenience.
- Quiet muffler (Whisper Series) with USDA FS certified spark arrester.
- Conveniently located multi-featured control panel with FIRMAN custom designed outlet cover protecting outlets from dirt, dust and debris.
- 4 in 1 Data-Minder monitors running hours, voltage and frequency in conjunction with our low oil indicator light.
- Durable compact roll-cage frame design with 1.0" steel tubing.
- FIRMAN new designed AVR (Automatic Voltage Regulator) VC (Volt-Lock) Series.
- Bonus accessories including engine oil, oil funnel and tool kit.
- 3 years warranty: best in industry.

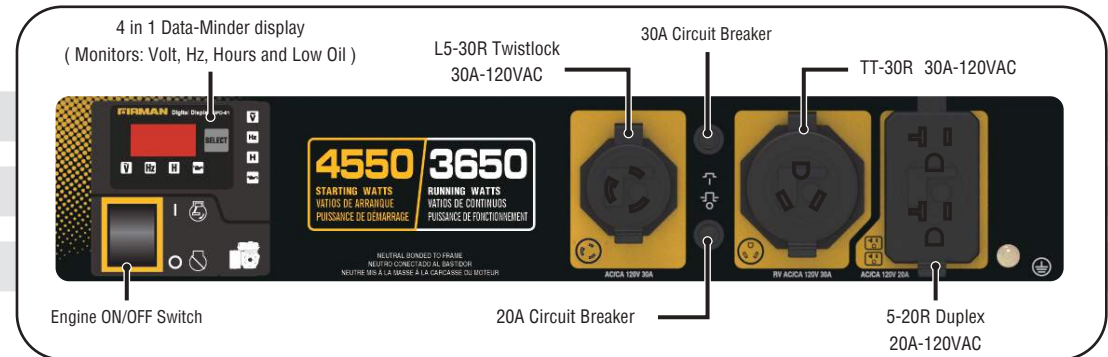

P03611

3650 Watts Generator

FIRMAN®

Performance series

Specification

Model /Rev Level	P03611 / 00
UPC	
49 States	Yes
California (CARB)	No
Canada (CSA)	No
Running Watts	3650
Starting Watts	4550
Frequency (Hz)	60
Engine Displacement (cc)	208
Engine Type	OHV
Starting System	Recoil
Cylinder	Single
Fuel Type	Gasoline
Low Oil Shutdown	Yes
Cast Iron Sleeve	Yes
Brushed or Brushless Alternator	Brushed
Automatic Voltage Regulator (AVR)	Yes
Fuel Tank Volume (Gal)	5.0
Fuel Gauge	Yes
Runtime @50% load (hours)	14.0
USDA FS Certified Spark Arrester	Yes



Handle	No
Wheel	No
Battery	No
Accessories	Oil Bottle-Funnel-Tool Kit
Warranty Residential / Commercial (years)	3 / 1
Carton LxWxH (inch)	24 x 18.1 x 19.9
Unit Weight (lbs)	101.5
Shipping Weight (lbs)	110

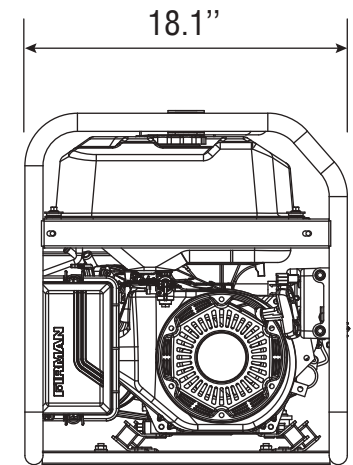
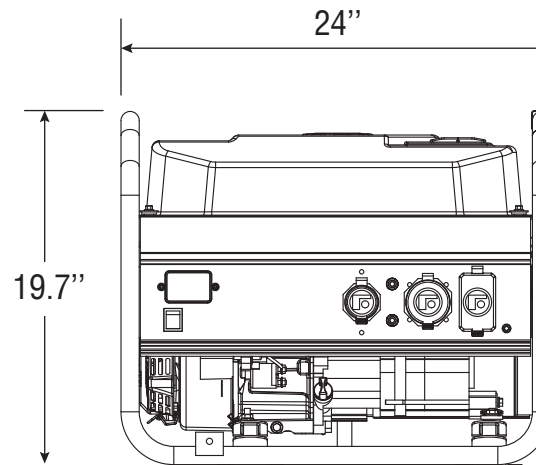

FIRMAN

www.firmangenerators.com

P05701

5700 Watts Generator

FIRMAN®

Performance series

Running / Starting Watts: 5700/7125



Features & Benefits

- The FIRMAN OHV engine (Max-Pro Series) for longer life/higher performance/lower maintenance.
- Cast iron sleeved (CIS) engine for long durability with automatic low oil shutdown (LOS) protection.
- Largest tank in industry with extended run-time (less re-fueling) with built-in tank gauge for convenience.
- Quiet muffler (Whisper Series) with USDA FS certified spark arrester.
- Conveniently located multi-featured control panel with FIRMAN custom designed outlet cover protecting outlets from dirt, dust and debris.
- 4 in 1 Data-Minder monitors running hours, voltage and frequency in conjunction with our low oil indicator light.
- Wheel Kit with heavy duty and over size flat free wheels with high leverage single folding handle with grip for easy maneuver.
- Durable compact roll-cage frame design with 1.2" steel tubing.
- FIRMAN new designed AVR (Automatic Voltage Regulator) VC (Volt-Lock) Series.
- Bonus accessories including engine oil, oil funnel and tool kit.
- 3 years warranty: best in industry.

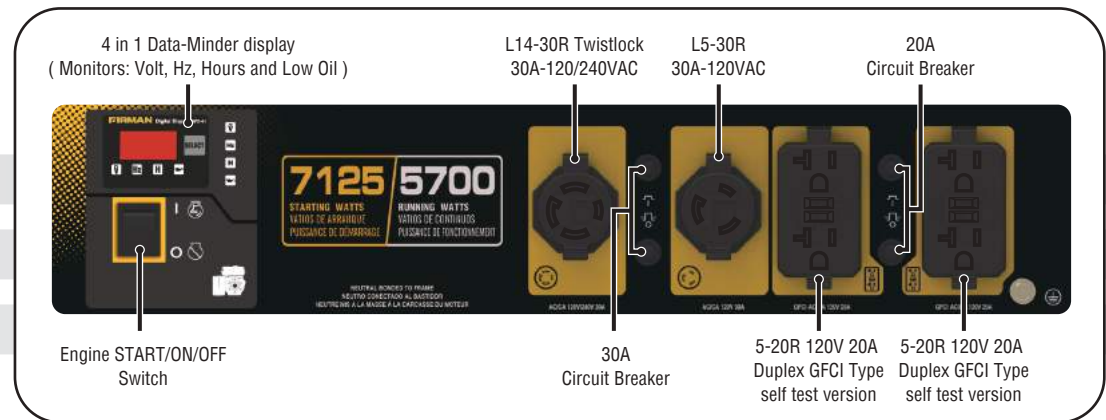

P05701

5700 Watts Generator

FIRMAN®

Performance series

Specification

Model /Rev Level	P05701 / 00
UPC	840876157015
49 States	Yes
California (CARB)	No
Canada (CSA)	No
Running Watts	5700
Starting Watts	7125
Frequency (Hz)	60
Engine Displacement (cc)	389
Engine Type	OHV
Starting System	Recoil
Cylinder	Single
Fuel Type	Gasoline
Low Oil Shutdown	Yes
Cast Iron Sleeve	Yes
Brushed or Brushless Alternator	Brushed
Automatic Voltage Regulator (AVR)	Yes
Fuel Tank Volume (Gal)	8.0
Fuel Gauge	Yes
Runtime @50% load (hours)	13.0
USDA FS Certified Spark Arrester	Yes



Handle	Single Folding
Wheel	10.0" Flat Free
Battery	No
Accessories	Oil Bottle-Funnel-Tool Kit
Warranty Residential / Commercial (years)	3 / 1
Carton LxWxH (inch)	31.7 x 21.7 x 24.4
Unit Weight (lbs)	178
Shipping Weight (lbs)	188.5

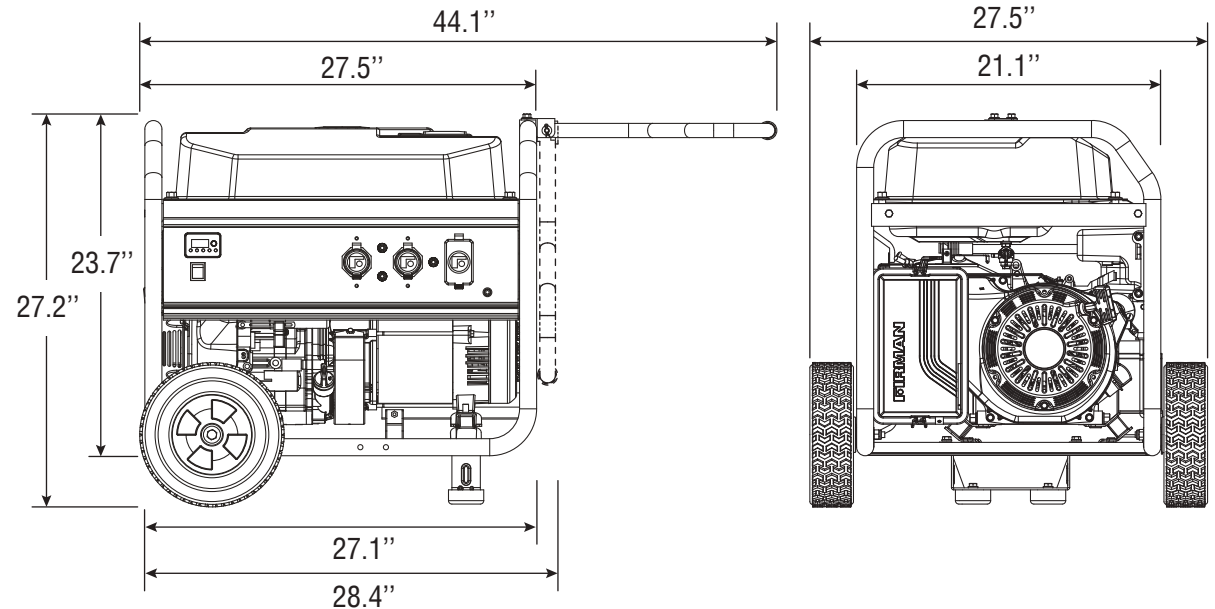

FIRMAN

www.firmangenerators.com

P05702

5700 Watts Generator



Performance series

Running / Starting Watts: 5700/7125

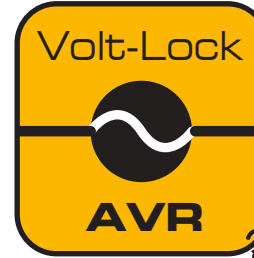

Features & Benefits

- The FIRMAN OHV engine (Max-Pro Series) for longer life/higher performance/lower maintenance.
- Cast iron sleeved (CIS) engine for long durability with automatic low oil shutdown (LOS) protection.
- Largest tank in industry with extended run-time (less re-fueling) with built-in tank gauge for convenience.
- Quiet muffler (Whisper Series) with USDA FS certified spark arrester.
- Conveniently located multi-featured control panel with FIRMAN custom designed outlet cover protecting outlets from dirt, dust and debris.
- 4 in 1 Data-Minder monitors running hours, voltage and frequency in conjunction with our low oil indicator light.
- Wheel Kit with heavy duty and over size flat free wheels with high leverage single folding handle with grip for easy maneuver.
- Durable compact roll-cage frame design with 1.2" steel tubing.
- FIRMAN new designed AVR (Automatic Voltage Regulator) VC (Volt-Lock) Series.
- Bonus accessories including engine oil, oil funnel and tool kit.
- 3 years warranty: best in industry.

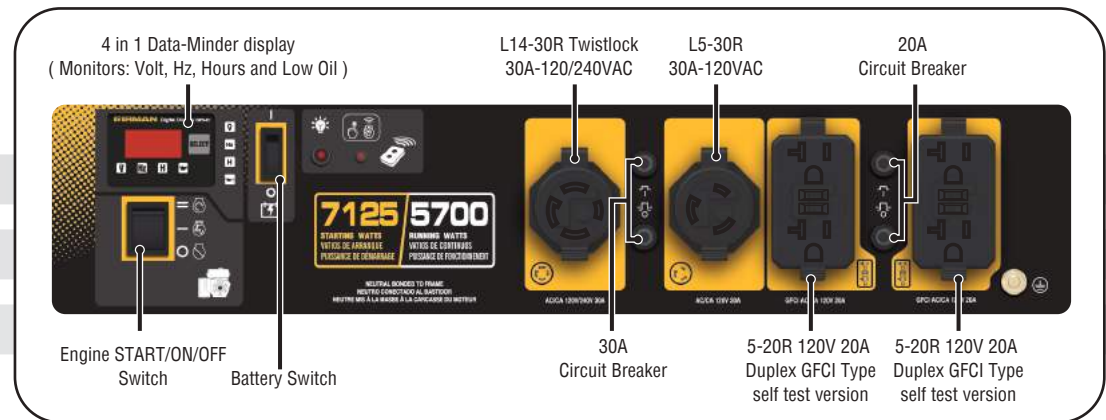

P05702

5700 Watts Generator

FIRMAN®

Performance series

Specification

Model /Rev Level	P05702 / 00
UPC	840876157022
49 States	Yes
California (CARB)	No
Canada (CSA)	No
Running Watts	5700
Starting Watts	7125
Frequency (Hz)	60
Engine Displacement (cc)	389
Engine Type	OHV
Starting System	Recoil
Cylinder	Single
Fuel Type	Gasoline
Low Oil Shutdown	Yes
Cast Iron Sleeve	Yes
Brushed or Brushless Alternator	Brushed
Automatic Voltage Regulator (AVR)	Yes
Fuel Tank Volume (Gal)	8.0
Fuel Gauge	Yes
Runtime @50% load (hours)	13.0
USDA FS Certified Spark Arrester	Yes



Handle	Single Folding
Wheel	10.0" Flat Free
Battery	Yes
Accessories	Oil Bottle-Funnel-Tool Kit
Warranty Residential / Commercial (years)	3 / 1
Carton LxWxH (inch)	31.7 x 21.7 x 24.4
Unit Weight (lbs)	178
Shipping Weight (lbs)	188.5

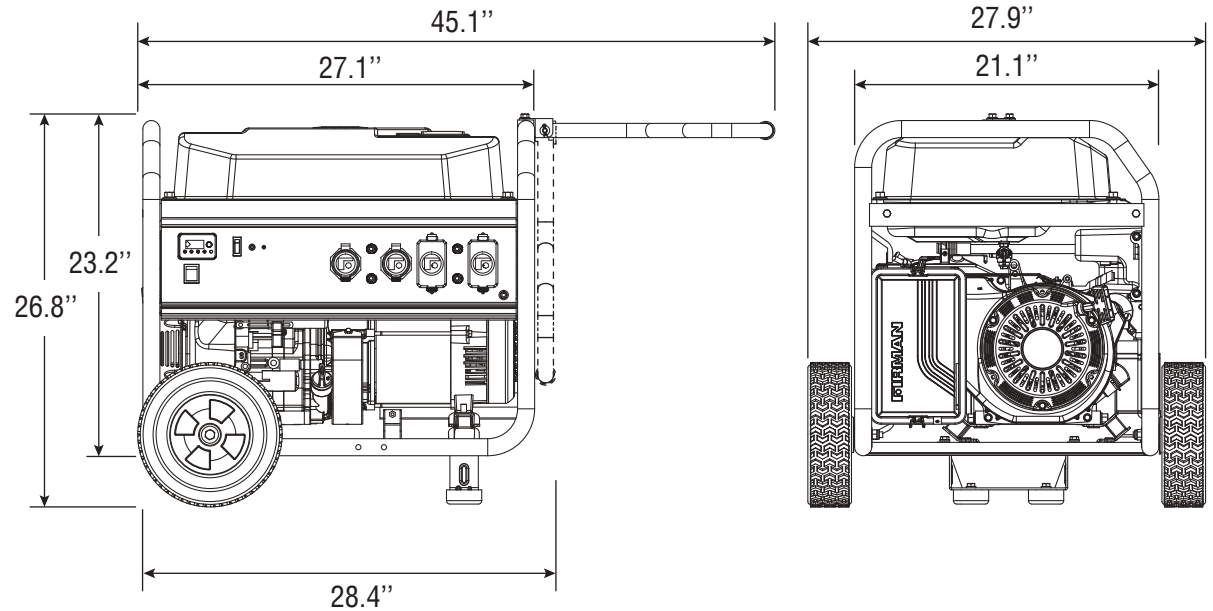

FIRMAN

www.firmangenerators.com

P08003

8000 Watts Generator

FIRMAN®

Performance series

Running / Starting Watts: 8000/10000



Features & Benefits

- The FIRMAN OHV engine (Max-Pro Series) for longer life/higher performance/lower maintenance.
- Cast iron sleeved (CIS) engine for long durability with automatic low oil shutdown (LOS) protection.
- Largest tank in industry with extended run-time (less re-fueling) with built-in tank gauge for convenience.
- Quiet muffler (Whisper Series) with USDA FS certified spark arrester.
- Conveniently located multi-featured control panel with FIRMAN custom designed outlet cover protecting outlets from dirt, dust and debris.
- 4 in 1 Data-Minder monitors running hours, voltage and frequency in conjunction with our low oil indicator light.
- Wheel Kit with heavy duty and over size flat free wheels with high leverage single folding handle with grip for easy maneuver.
- Durable compact roll-cage frame design with 1.2" steel tubing.
- FIRMAN new designed AVR (Automatic Voltage Regulator) VC (Volt-Lock) Series.
- Bonus accessories including engine oil, oil funnel and tool kit.
- 3 years warranty: best in industry.

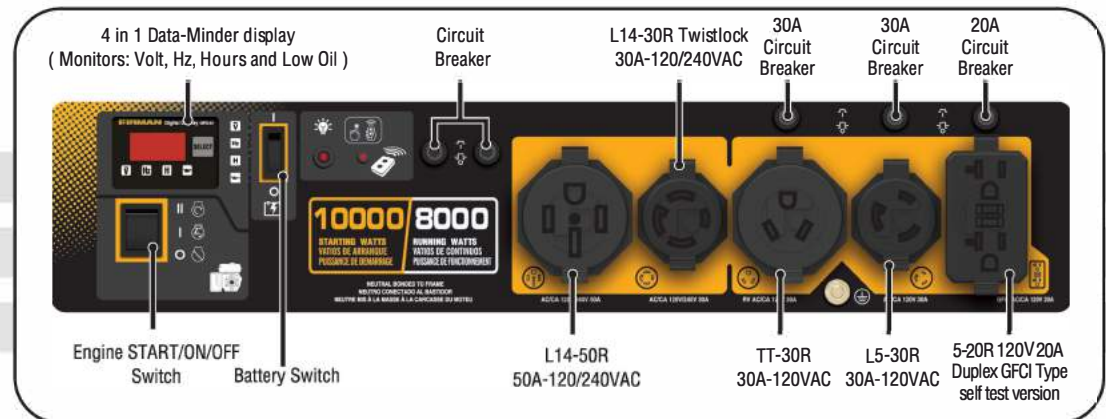

P08003

8000 Watts Generator



Performance series

Specification

Model /Rev Level	P08003 / 00
UPC	840876180037
49 States	Yes
California (CARB)	No
Canada (CSA)	No
Running Watts	8000
Starting Watts	10000
Frequency (Hz)	60
Engine Displacement (cc)	439
Engine Type	OHV
Starting System	Recoil / Electric
Cylinder	Single
Fuel Type	Gasoline
Low Oil Shutdown	Yes
Cast Iron Sleeve	Yes
Brushed or Brushless Alternator	Brushed
Automatic Voltage Regulator (AVR)	Yes
Fuel Tank Volume (Gal)	8.0
Fuel Gauge	Yes
Runtime @50% load (hours)	12.0
USDA FS Certified Spark Arrester	Yes



Handle	Single Folding
Wheel	10.0" Flat Free
Battery	Yes
Accessories	Oil Bottle-Funnel-Tool Kit
Warranty Residential / Commercial (years)	3 / 1
Carton LxWxH (inch)	31.7 x 21.7 x 24.4
Unit Weight (lbs)	210.3
Shipping Weight (lbs)	237.6

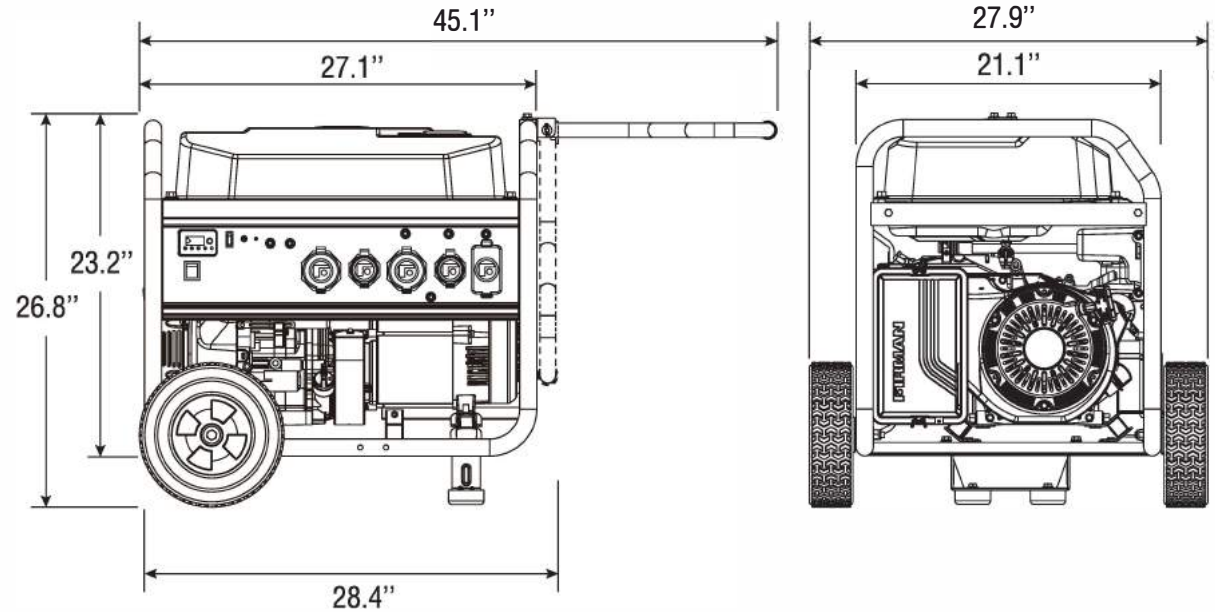

W01781

1700 Watts Generator

FIRMAN®

Whisper series

Running / Starting Watts: 1700/2100

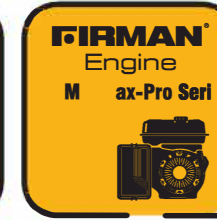
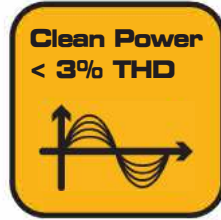

Features & Benefits

- The FIRMAN OHV engine (Max-Pro Series) for longer life/higher performance/lower maintenance.
- Cast iron sleeved (CIS) engine for long durability with automatic low oil shutdown (LOS) protection.
- Largest tank in industry with extended run-time (less re-fueling).
- Quiet muffler (Whisper Series) with USDA FS certified spark arrester.
- Conveniently located multi-featured control panel with FIRMAN custom designed outlet cover protecting outlets from dirt, dust and debris.
- Bonus accessories including engine oil, oil funnel, tool kit and battery charge cable.
- 3 years warranty.

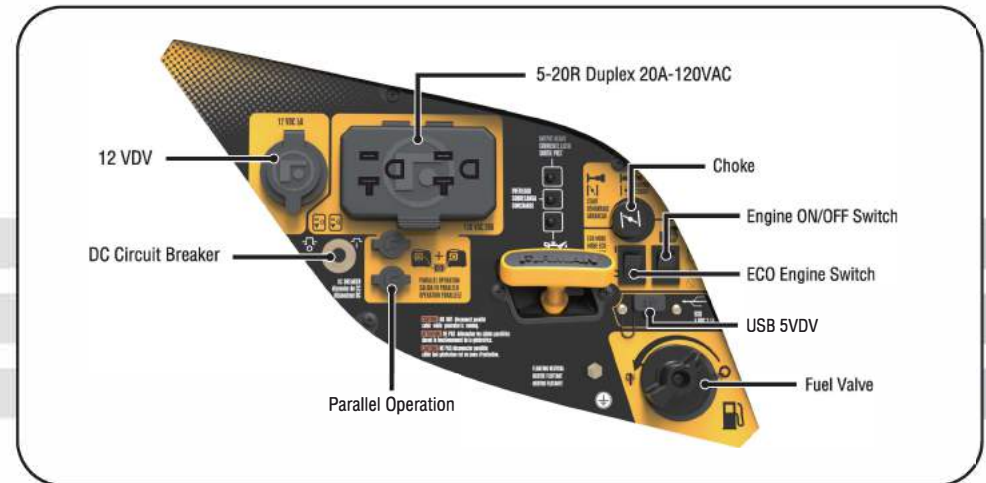

W01781

1700 Watts Generator



Whisper series

Specification

Model /Rev Level	W01781 / 01
UPC	840876117811
50 States	Yes
California (CARB)	Yes
Canada (CSA)	Yes
Running Watts	1700
Starting Watts	2100
Frequency (Hz)	60
Engine Displacement (cc)	80
Engine Type	OHV
Starting System	Recoil
Cylinder	Single
Fuel Type	Gasoline
Low Oil Shutdown	Yes
Cast Iron Sleeve	Yes
Brushed or Brushless Alternator	Brushless
Inverter	Yes
Fuel Tank Volume (Gal)	0.9
Fuel Gauge	No
Runtime @25% load (hours)	9.0
USDA FS Certified Spark Arrester	Yes



Battery	No
Accessories	Oil Bottle-Funnel-Tool Kit -Battery Charger Cable
Warranty Residential / Commercial (years)	3 / 1
Carton LxWxH (inch)	21.7 x 15.0 x 18.3
Unit Weight (lbs)	45.9
Shipping Weight (lbs)	51.6

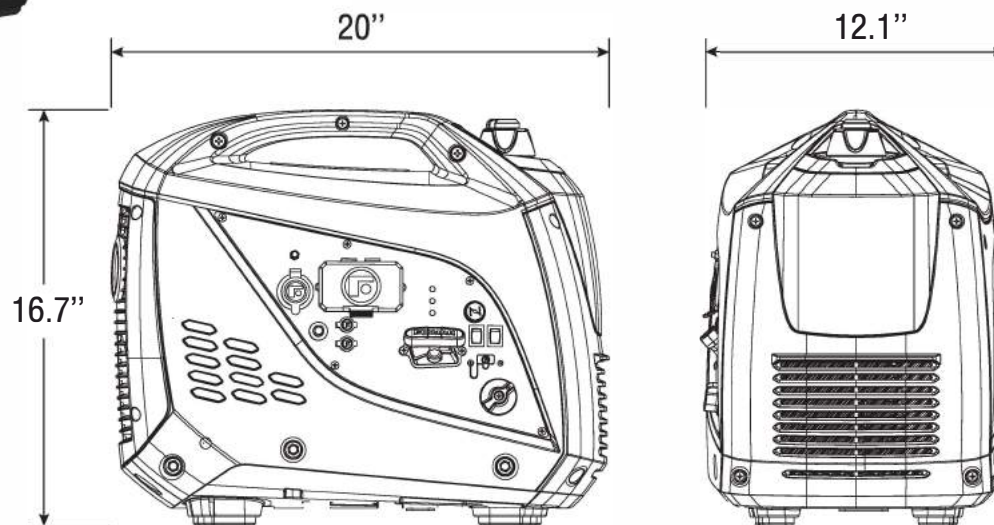

W03081

3000 Watts Generator

FIRMAN®

Whisper series

Running / Starting Watts: 3000/3300



Features & Benefits

- The FIRMAN OHV engine (Max-Pro Series) for longer life/higher performance/lower maintenance.
- Cast iron sleeved (CIS) engine for long durability with automatic low oil shutdown (LOS) protection.
- Largest tank in industry with extended run-time (less re-fueling).
- Quiet muffler (Whisper Series) with USDA FS certified spark arrester.
- Conveniently located multi-featured control panel with FIRMAN custom designed outlet cover protecting outlets from dirt, dust and debris.
- 3 in 1 Data-Minder monitors running hours, voltage and frequency in conjunction.
- Bonus accessories including engine oil, oil funnel, tool kit and battery charge cable.
- 3 years warranty: best in industry.

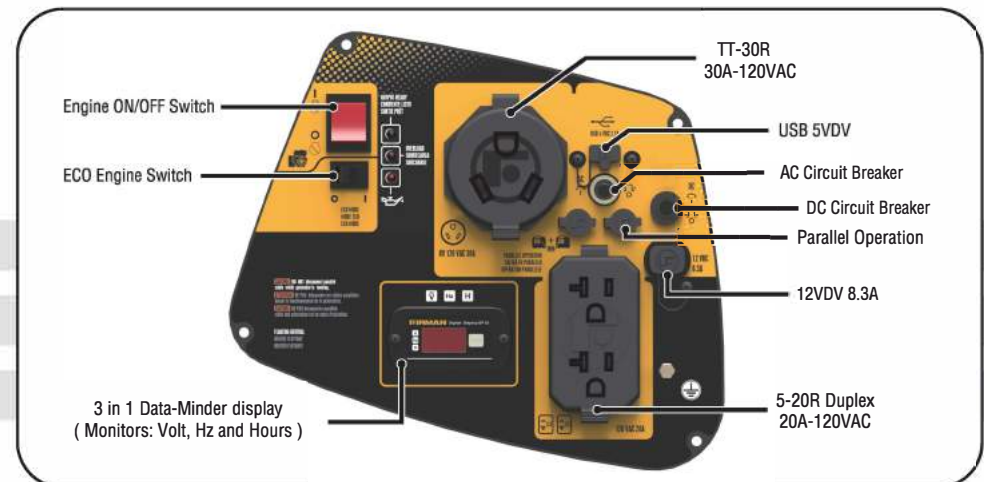

W03081

3000 Watts Generator

FIRMAN®

Whisper series

Specification

Model /Rev Level	W03081 / 00
UPC	840876130810
50 States	Yes
California (CARB)	Yes
Canada (CSA)	Yes
Running Watts	3000
Starting Watts	3300
Frequency (Hz)	60
Engine Displacement (cc)	171
Engine Type	OHV
Starting System	Recoil
Cylinder	Single
Fuel Type	Gasoline
Low Oil Shutdown	Yes
Cast Iron Sleeve	Yes
Brushed or Brushless Alternator	Brushless
Inverter	Yes
Fuel Tank Volume (Gal)	1.8
Fuel Gauge	No
Runtime @25% load (hours)	9.0
USDA FS Certified Spark Arrester	Yes



Battery	No
Accessories	Oil Bottle-Funnel-Tool Kit -Battery Charger Cable
Warranty Residential / Commercial (years)	3 / 1
Carton LxWxH (inch)	26.6 x 18.9 x 19.3
Unit Weight (lbs)	82
Shipping Weight (lbs)	92

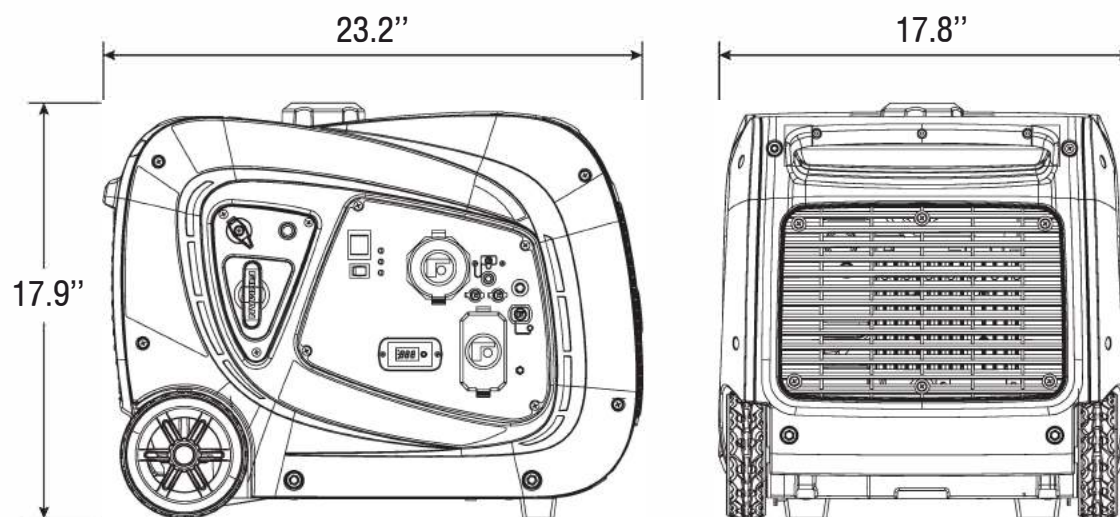

W03082

3000 Watts Generator

FIRMAN®

Whisper series

Running / Starting Watts: 3000/3300



Features & Benefits

- The FIRMAN OHV electric start engine (Max-Pro Series) for longer life/higher performance/lower maintenance.
- Cast iron sleeved (CIS) engine for long durability with automatic low oil shutdown (LOS) protection.
- Largest tank in industry with extended run-time (less re-fueling).
- Quiet muffler (Whisper Series) with USDA FS certified spark arrester.
- Conveniently located multi-featured control panel with FIRMAN custom designed outlet cover protecting outlets from dirt, dust and debris.
- 3 in 1 Data-Minder monitors running hours, voltage and frequency in conjunction.
- Bonus accessories including engine oil, oil funnel, tool kit and battery charge cable.
- 3 years warranty: best in industry.

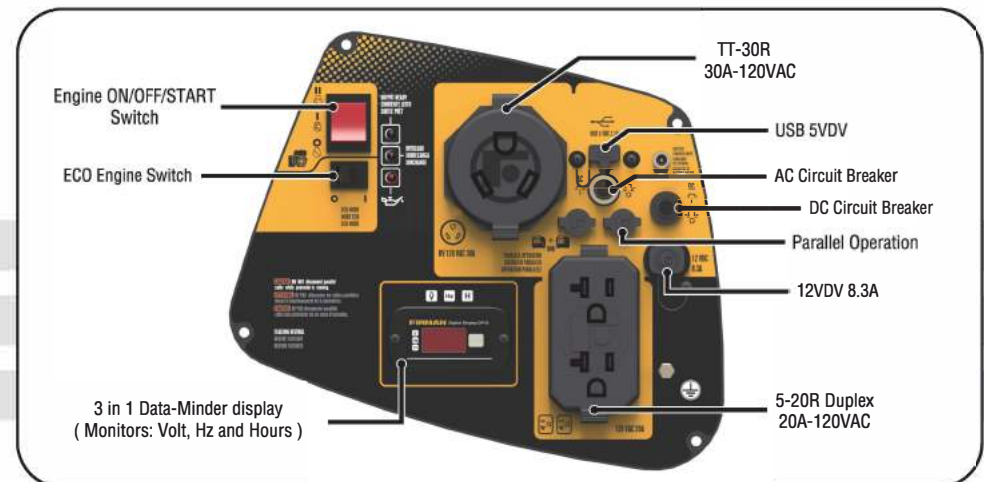

W03082

3000 Watts Generator

FIRMAN®

Whisper series

Specification

Model /Rev Level	W03082 / 00
UPC	840876130827
50 States	Yes
California (CARB)	Yes
Canada (CSA)	Yes
Running Watts	3000
Starting Watts	3300
Frequency (Hz)	60
Engine Displacement (cc)	171
Engine Type	OHV
Starting System	Recoil / Electric
Cylinder	Single
Fuel Type	Gasoline
Low Oil Shutdown	Yes
Cast Iron Sleeve	Yes
Brushed or Brushless Alternator	Brushless
Inverter	Yes
Fuel Tank Volume (Gal)	1.8
Fuel Gauge	Yes
Runtime @25% load (hours)	9.0
USDA FS Certified Spark Arrester	Yes



Battery	Yes
Accessories	Oil Bottle-Funnel-Tool Kit -Battery Charger Cable
Warranty Residential / Commercial (years)	3 / 1
Carton LxWxH (inch)	26.6 x 18.9 x 19.3
Unit Weight (lbs)	TBD
Shipping Weight (lbs)	TBD

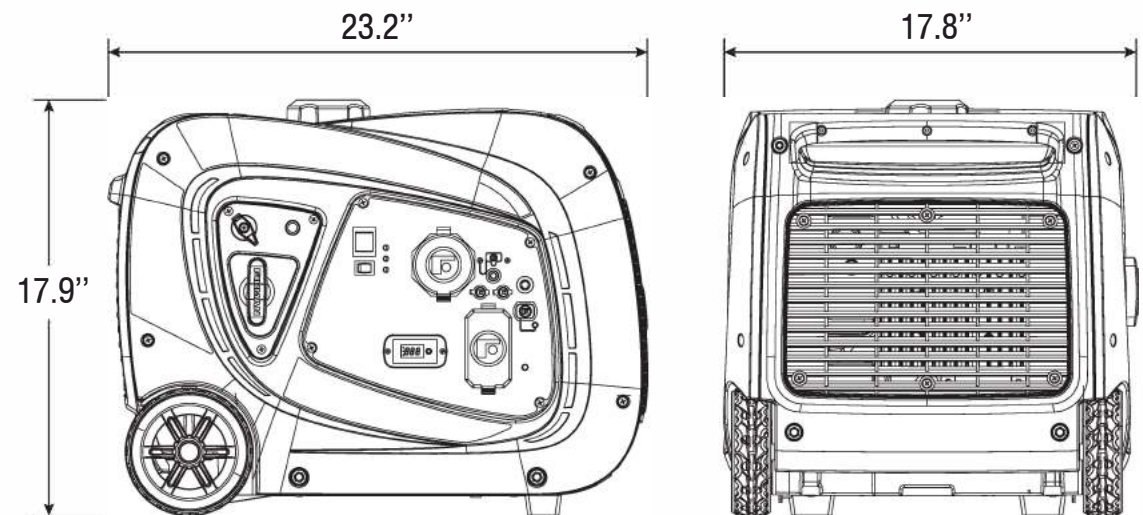

W03083

3000 Watts Generator

FIRMAN®

Whisper series

Running / Starting Watts: 3000/3300

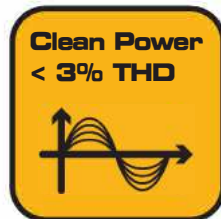

Features & Benefits

- The FIRMAN OHV remote start engine (Max-Pro Series) for longer life/higher performance/lower maintenance.
- Cast iron sleeved (CIS) engine for long durability with automatic low oil shutdown (LOS) protection.
- Largest tank in industry with extended run-time (less re-fueling).
- Quiet muffler (Whisper Series) with USDA FS certified spark arrester.
- Conveniently located multi-featured control panel with FIRMAN custom designed outlet cover protecting outlets from dirt, dust and debris.
- 3 in 1 Data-Minder monitors running hours, voltage and frequency in conjunction.
- Bonus accessories including engine oil, oil funnel, tool kit and battery charge cable.
- 3 years warranty: best in industry.

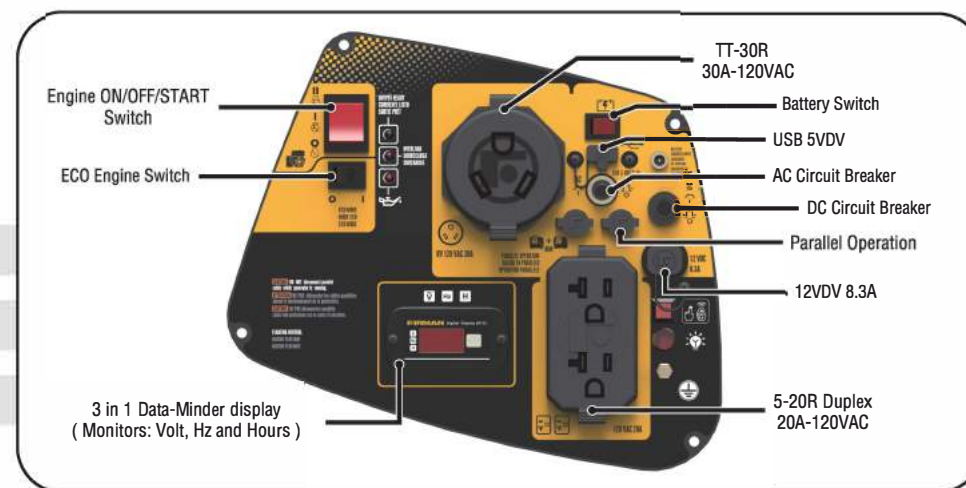

W03083

3000 Watts Generator



Whisper series

Specification

Model /Rev Level	W03083 / 00
UPC	840876130834
50 States	Yes
California (CARB)	Yes
Canada (CSA)	Yes
Running Watts	3000
Starting Watts	3300
Frequency (Hz)	60
Engine Displacement (cc)	171
Engine Type	OHV
Starting System	Recoil/Electric/Remote
Cylinder	Single
Fuel Type	Gasoline
Low Oil Shutdown	Yes
Cast Iron Sleeve	Yes
Brushed or Brushless Alternator	Brushless
Inverter	Yes
Fuel Tank Volume (Gal)	1.8
Fuel Gauge	Yes
Runtime @25% load (hours)	9.0
USDA FS Certified Spark Arrester	Yes



Battery	Yes
Accessories	Oil Bottle-Funnel-Tool Kit -Battery Charger Cable
Warranty Residential / Commercial (years)	3 / 1
Carton LxWxH (inch)	26.6 x 18.9 x 19.3
Unit Weight (lbs)	TBD
Shipping Weight (lbs)	TBD

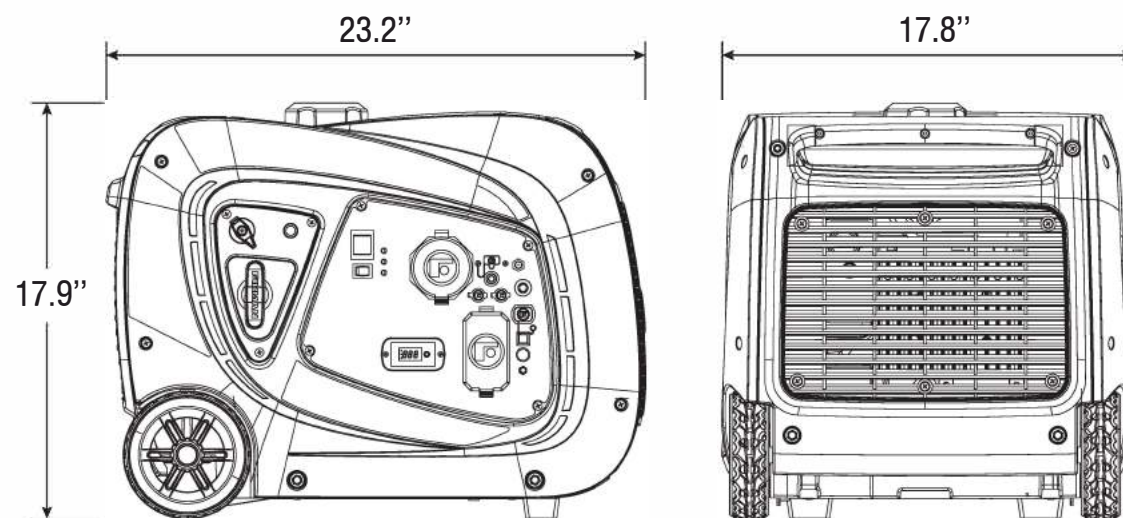



H03651

Hybrid Series

FIRMAN®

Running/Starting Watts: 3300/4100

Running/Starting Watts: 3650/4550



Features & Benefits

- Runs on gasoline or propane fuel, giving you flexibility while out on the road or during an emergency.
- Extended propane regulator/hose (5ft) for convenience when running off of a larger propane tank.
- The FIRMAN OHV engine (Max-Pro Series) for longer life/higher performance/lower maintenance.
- FIRMAN newly designed AVR (Automatic Voltage Regulator) VL (Volt-Lock) Series.
- Cast iron sleeved engine for long durability with automatic low oil shutdown protection.
- Largest tank in the industry with extended run-time (less re-fueling) with integrated fuel gauge for convenience.
- Quiet muffler (Whisper Series) with USDA FS certified spark arrester.
- Conveniently located multi-featured control panel with FIRMAN custom designed outlet cover protecting outlets from dirt, dust and debris.
- 3 in 1 Data-Minder monitors running hours, voltage and frequency.
- Wheel Kit with heavy duty and over size flat free wheels with high leverage single folding handle with grip for easy maneuver.
- Durable compact roll-cage frame design with 1.0" steel tubing.
- Bonus accessories including engine oil, oil funnel and tool kit.
- Included battery for your convenience.
- 3 year warranty: best in industry.

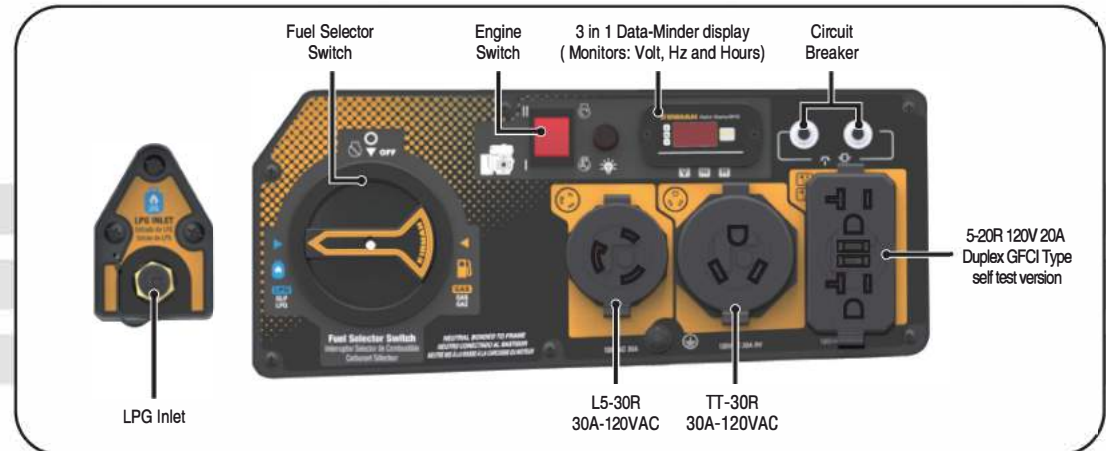



H03651

Hybrid Series



Specification

Model /Rev Level	P03651 / 00
UPC	840876136515
49 States	Yes
California (CARB)	No
Canada (CETL)	No
LPG Running Watts	3300
LPG Starting Watts	4100
GAS Running Watts	3650
GAS Starting Watts	4550
Frequency (Hz)	60
Engine Displacement (cc)	208
Engine Type	OHV
Starting System	Recoil/Electric
Cylinder	Single
Fuel Type	Gasoline/LPG
Low Oil Shutdown	Yes
Cast Iron Sleeve	Yes
Brushed or Brushless Alternator	Brushed
Automatic Voltage Regulator (AVR)	Yes
Fuel Tank Volume (Gal)	5.0
Fuel Gauge	Yes
Runtime @50% load (hours)	14.0
USDA FS Certified Spark Arrester	Yes



Handle	Single Folding
Wheel	8.0" Flat Free
Battery	Yes
Accessories	Wheel kit-Oil Bottle Funnel-Tool Kit
Warranty Residential / Commercial	3 years / 90 days
Carton LxWxH (inch)	27.9 x 18.1 x 20.5
Unit Weight (lbs)	N/A
Shipping Weight (lbs)	N/A

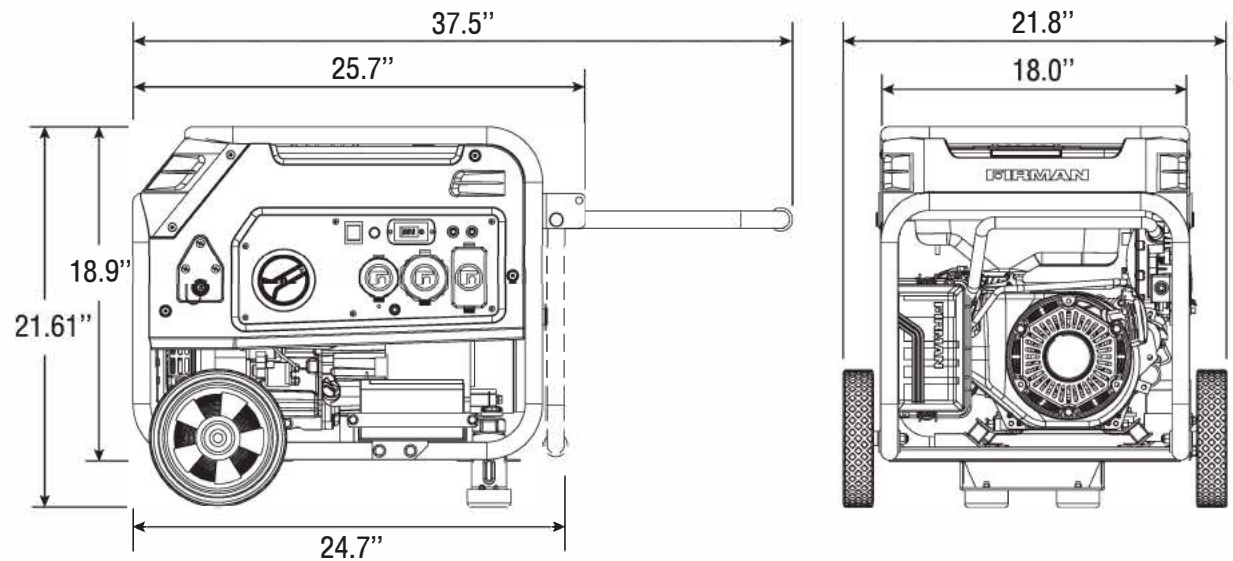



H03652

Hybrid Series



Running/Starting Watts: 3300/4100

Running/Starting Watts: 3650/4550



Features & Benefits

- Runs on gasoline or propane fuel, giving you flexibility while out on the road or during an emergency.
- Extended propane regulator/hose (5ft) for convenience when running off of a larger propane tank.
- The FIRMAN OHV engine (Max-Pro Series) for longer life/higher performance/lower maintenance.
- FIRMAN newly designed AVR (Automatic Voltage Regulator) VL (Volt-Lock) Series.
- Cast iron sleeved engine for long durability with automatic low oil shutdown protection.
- Largest tank in the industry with extended run-time (less re-fueling) with integrated fuel gauge for convenience.
- Quiet muffler (Whisper Series) with USDA FS certified spark arrester.
- Conveniently located multi-featured control panel with FIRMAN custom designed outlet cover protecting outlets from dirt, dust and debris.
- 3 in 1 Data-Minder monitors running hours, voltage and frequency.
- Wheel Kit with heavy duty and over size flat free wheels with high leverage single folding handle with grip for easy maneuver.
- Durable compact roll-cage frame design with 1.0" steel tubing.
- Bonus accessories including engine oil, oil funnel and tool kit.
- 3 year warranty: best in industry.







H03652

Hybrid Series



Specification

Model /Rev Level	P03652 / 00
UPC	840876136522
49 States	Yes
California (CARB)	No
Canada (CETL)	No
 LPG Running Watts	3300
 LPG Starting Watts	4100
 GAS Running Watts	3650
 GAS Starting Watts	4550
Frequency (Hz)	60
Engine Displacement (cc)	208
Engine Type	OHV
Starting System	Recoil
Cylinder	Single
Fuel Type	Gasoline/LPG
Low Oil Shutdown	Yes
Cast Iron Sleeve	Yes
Brushed or Brushless Alternator	Brushed
Automatic Voltage Regulator (AVR)	Yes
Fuel Tank Volume (Gal)	5.0
Fuel Gauge	Yes
Runtime @50% load (hours)	14.0
USDA FS Certified Spark Arrester	Yes



Handle	Single Folding
Wheel	8.0" Flat Free
Battery	No
Accessories	Wheel kit-Oil Bottle Funnel-Tool Kit
Warranty Residential / Commercial	3 years / 90 days
Carton LxWxH (inch)	27.9 x 18.1 x 20.5
Unit Weight (lbs)	N/A
Shipping Weight (lbs)	N/A

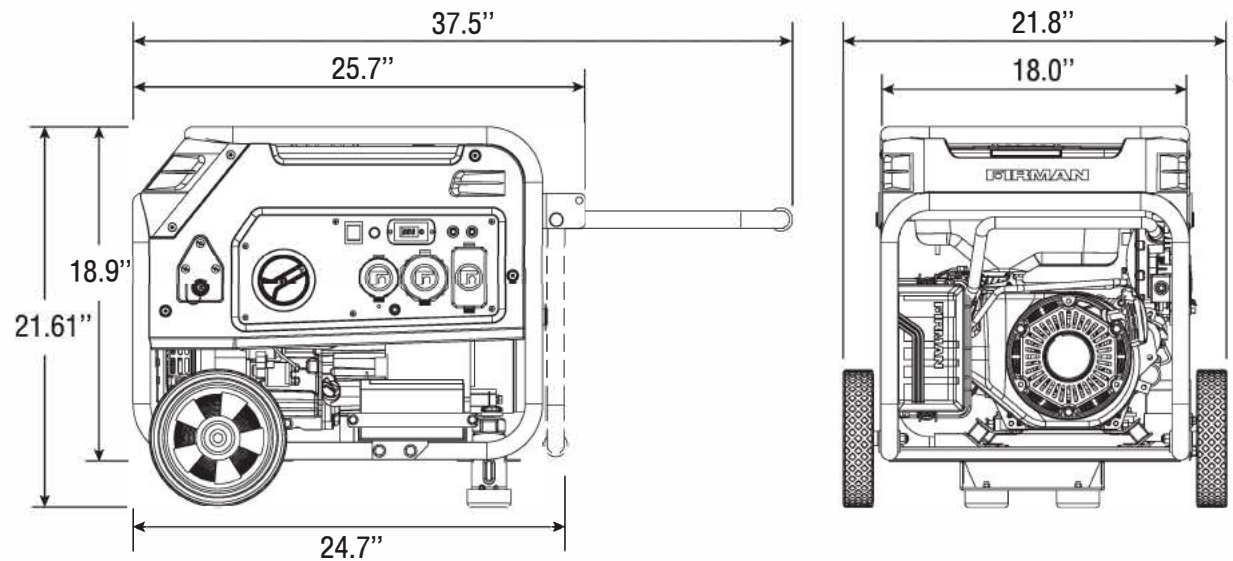



H05751

Hybrid Series

FIRMAN®

Running/Starting Watts: 5700/7125

Running/Starting Watts: 5700/7125



Features & Benefits

- Runs on gasoline or propane fuel, giving you flexibility while out on the road or during an emergency.
- Extended propane regulator/hose (5ft) for convenience when running off of a larger propane tank.
- The FIRMAN OHV engine (Max-Pro Series) for longer life/higher performance/lower maintenance.
- FIRMAN newly designed AVR (Automatic Voltage Regulator) VL (Volt-Lock) Series.
- Cast iron sleeved engine for long durability with automatic low oil shutdown protection.
- Largest tank in the industry with extended run-time (less re-fueling) with integrated fuel gauge for convenience.
- Quiet muffler (Whisper Series) with USDA FS certified spark arrester.
- Conveniently located multi-featured control panel with FIRMAN custom designed outlet cover protecting outlets from dirt, dust and debris.
- 3 in 1 Data-Minder monitors running hours, voltage and frequency.
- Wheel Kit with heavy duty and over size flat free wheels with high leverage single folding handle with grip for easy maneuver.
- Durable compact roll-cage frame design with 1.2" steel tubing.
- Bonus accessories including engine oil, oil funnel and tool kit.
- Included battery for your convenience.
- 3 year warranty: best in industry.

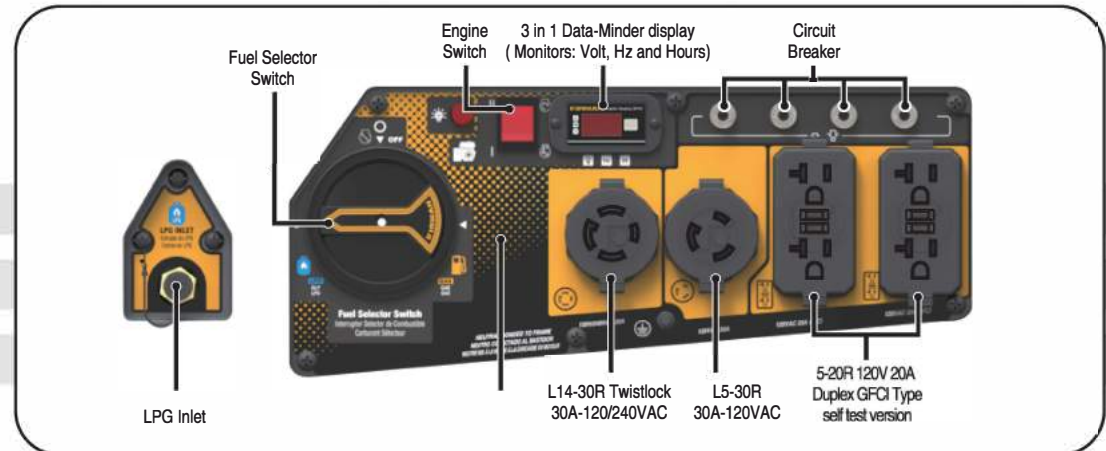



H05751

Hybrid Series



Specification

Model /Rev Level	P05751 / 00
UPC	840876157510
49 States	Yes
California (CARB)	Yes
Canada (ETL)	No
LPG Running Watts	5700
LPG Starting Watts	7125
GAS Running Watts	5700
GAS Starting Watts	7125
Frequency (Hz)	60
Engine Displacement (cc)	439
Engine Type	OHV
Starting System	Recoil/Electric
Cylinder	Single
Fuel Type	Gasoline/LPG
Low Oil Shutdown	Yes
Cast Iron Sleeve	Yes
Brushed or Brushless Alternator	Brushed
Automatic Voltage Regulator (AVR)	Yes
Fuel Tank Volume (Gal)	8.0
Fuel Gauge	Yes
Runtime @50% load (hours)	13.0
USDA FS Certified Spark Arrester	Yes



Handle	Single Folding
Wheel	10.0" Flat Free
Battery	Yes
Accessories	Wheel kit-Oil Bottle Funnel-Tool Kit
Warranty Residential / Commercial	3 years / 90 days
Carton LxWxH (inch)	32.1 x 22.2 x 24.4
Unit Weight (lbs)	N/A
Shipping Weight (lbs)	N/A

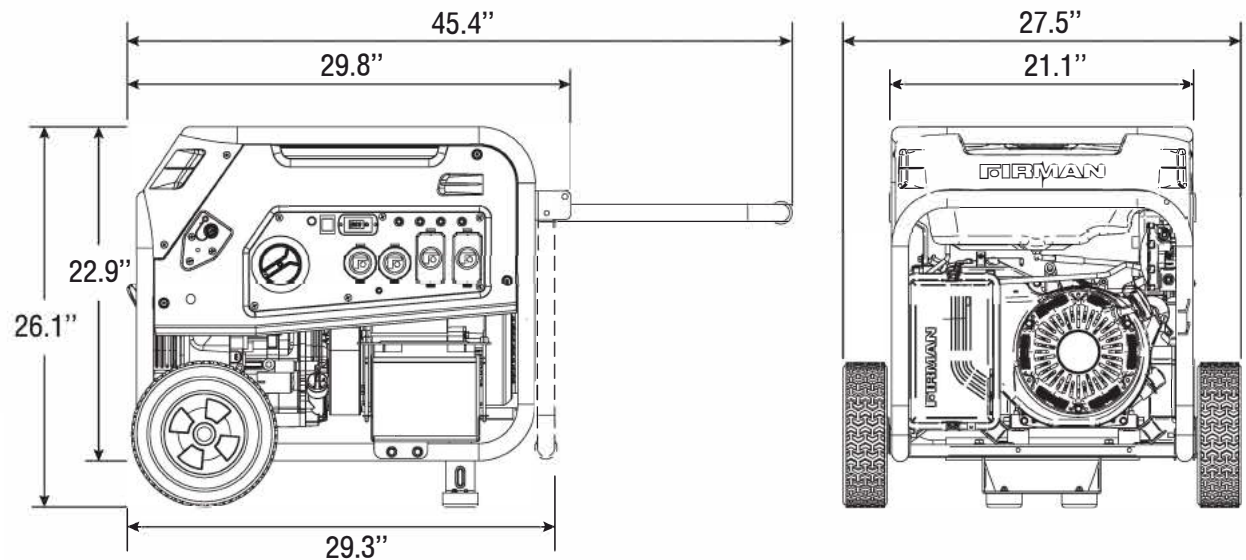



H05752

Hybrid Series

FIRMAN®

 Running/Starting Watts: 5700/7125

 Running/Starting Watts: 5700/7125



Features & Benefits

- Runs on gasoline or propane fuel, giving you flexibility while out on the road or during an emergency.
- Extended propane regulator/hose (5ft) for convenience when running off of a larger propane tank.
- The FIRMAN OHV engine (Max-Pro Series) for longer life/higher performance/lower maintenance.
- FIRMAN newly designed AVR (Automatic Voltage Regulator) VL (Volt-Lock) Series.
- Cast iron sleeved engine for long durability with automatic low oil shutdown protection.
- Largest tank in the industry with extended run-time (less re-fueling) with integrated fuel gauge for convenience.
- Quiet muffler (Whisper Series) with USDA FS certified spark arrester.
- Conveniently located multi-featured control panel with FIRMAN custom designed outlet cover protecting outlets from dirt, dust and debris.
- 3 in 1 Data-Minder monitors running hours, voltage and frequency.
- Wheel Kit with heavy duty and over size flat free wheels with high leverage single folding handle with grip for easy maneuver.
- Durable compact roll-cage frame design with 1.2" steel tubing.
- Bonus accessories including engine oil, oil funnel and tool kit.
- 3 year warranty: best in industry.

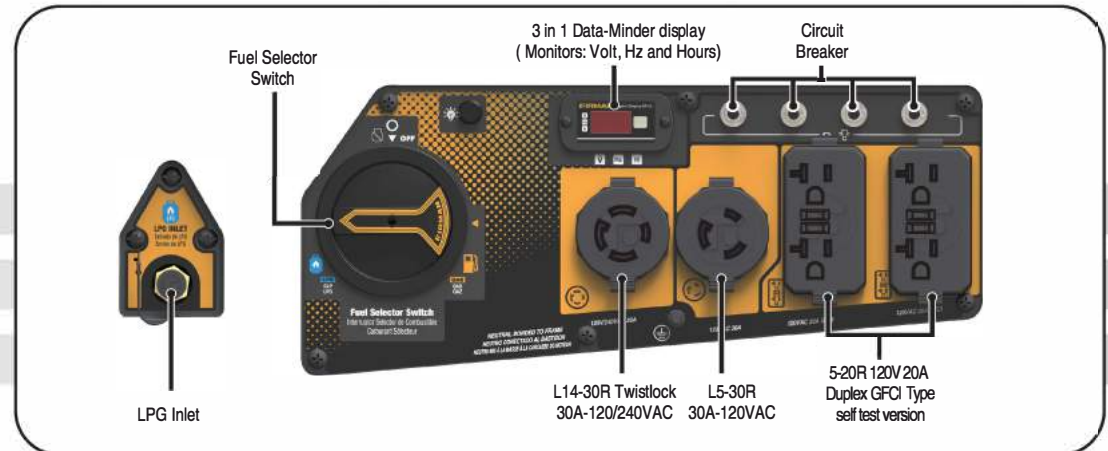





H05752

5700 Watts Generator



Hybrid Series

Specification

Model /Rev Level	P05752 / 00
UPC	840876157527
49 States	Yes
California (CARB)	Yes
Canada (CETL)	No
 LPG Running Watts	5700
LPG Starting Watts	7125
 GAS Running Watts	5700
GAS Starting Watts	7125
Frequency (Hz)	60
Engine Displacement (cc)	439
Engine Type	OHV
Starting System	Recoil
Cylinder	Single
Fuel Type	Gasoline/LPG
Low Oil Shutdown	Yes
Cast Iron Sleeve	Yes
Brushed or Brushless Alternator	Brushed
Automatic Voltage Regulator (AVR)	Yes
Fuel Tank Volume (Gal)	8.0
Fuel Gauge	Yes
Runtime @50% load (hours)	13.0
USDA FS Certified Spark Arrester	Yes



Handle	Single Folding
Wheel	10.0" Flat Free
Battery	No
Accessories	Wheel kit-Oil Bottle Funnel-Tool Kit
Warranty Residential / Commercial	3 years / 90 days
Carton LxWxH (inch)	32.1 x 22.2 x 24.4
Unit Weight (lbs)	N/A
Shipping Weight (lbs)	N/A

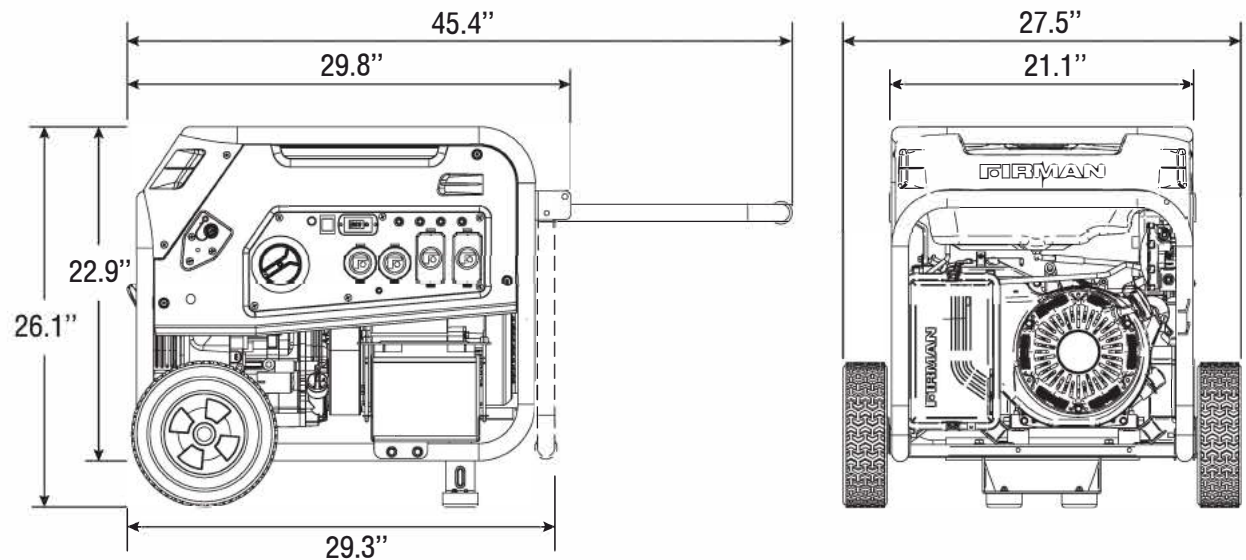



H08051

Hybrid Series

FIRMAN®

Running/Starting Watts: 7250/9050

Running/Starting Watts: 8000/10000



Features & Benefits

- Runs on gasoline or propane fuel, giving you flexibility while out on the road or during an emergency.
- Extended propane regulator/hose (5ft) for convenience when running off of a larger propane tank.
- The FIRMAN OHV engine (Max-Pro Series) for longer life/higher performance/lower maintenance.
- FIRMAN newly designed AVR (Automatic Voltage Regulator) VL (Volt-Lock) Series.
- Cast iron sleeved engine for long durability with automatic low oil shutdown protection.
- Largest tank in the industry with extended run-time (less re-fueling) with integrated fuel gauge for convenience.
- Quiet muffler (Whisper Series) with USDA FS certified spark arrester.
- Conveniently located multi-featured control panel with FIRMAN custom designed outlet cover protecting outlets from dirt, dust and debris.
- 3 in 1 Data-Minder monitors running hours, voltage and frequency.
- Wheel Kit with heavy duty and over size flat free wheels with high leverage single folding handle with grip for easy maneuver.
- Durable compact roll-cage frame design with 1.2" steel tubing.
- Bonus accessories including engine oil, oil funnel and tool kit.
- Included battery for your convenience.
- 3 year warranty: best in industry.

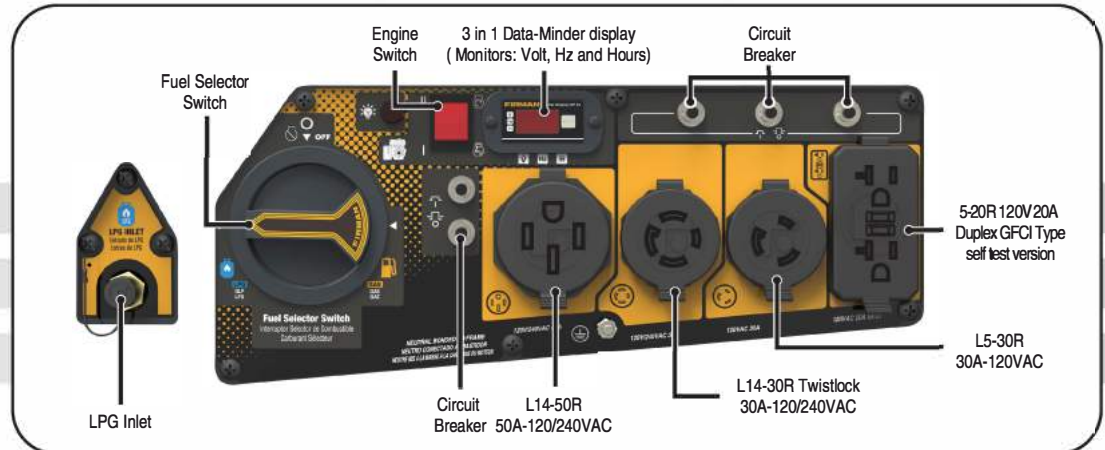





H08051

Hybrid Series



Specification

Model /Rev Level	P08051 / 00
UPC	840876180518
49 States	Yes
California (CARB)	Yes
Canada (CETL)	No
 LPG Running Watts	7250
LPG Starting Watts	9050
 GAS Running Watts	8000
GAS Starting Watts	10000
Frequency (Hz)	60
Engine Displacement (cc)	439
Engine Type	OHV
Starting System	Recoil/Electric
Cylinder	Single
Fuel Type	Gasoline/LPG
Low Oil Shutdown	Yes
Cast Iron Sleeve	Yes
Brushed or Brushless Alternator	Brushed
Automatic Voltage Regulator (AVR)	Yes
Fuel Tank Volume (Gal)	8.0
Fuel Gauge	Yes
Runtime @50% load (hours)	12.0
USDA FS Certified Spark Arrester	Yes



Handle	Single Folding
Wheel	10.0" Flat Free
Battery	Yes
Accessories	Wheel kit-Oil Bottle Funnel-Tool Kit
Warranty Residential / Commercial	3 years / 90 days
Carton LxWxH (inch)	32.1 x 22.2 x 24.4
Unit Weight (lbs)	202
Shipping Weight (lbs)	240

